



American
Timber and Steel



Fencing

- 2-3 *Round Fence Posts*
- 4 *Round Domed / Pointed Fence Posts*
- 5 *Round Faced Fence Posts*
- 6 *Board Fencing*
- 7 *Round Rail Fencing and Pre-Assembled Gates*
- 8-9 *Split Rail Fencing, Pre-Assembled Gates and Snake Rail Fencing*



Poles and Pilings

- 10 *Wood Piling*
- 11 *Utility Poles*
- 12 *No Taper Poles*
- 13 *Ranch Entrance Timber Kits and Custom Made Signs*



Timber Barrier Products

- 14 *Round Bollards and Dockside Kits*
- 15 *Square Bollards and Collapsible and Removable Bollards*
- 16-17 *Mortised and Notched Post & Rail*
- 18 *Square American Timber Rail*
- 19 *Round American Timber Rail*
- 20 *Log Rail*
- 21 *Merritt Parkway Guardrail*
- 22-23 *Steel-Backed Timber and Steel-Backed Log Rail*



Guardrail Products

- 24 *Wood Guardrail Posts and Blocks*
- 25 *Wood Product Stocking Locations*
- 26-27 *Steel Guardrail Components*
- 28 *Used Guardrail*
- 29 *Powder Coated Guardrail*



Timbers

- 30 *Sign Post and Box Beam Sign Posts*
- 31 *Timber Lagging and Landscape Timbers*
- 32-33 *Covered Bridge Timbers*
- 34 *Bridge Decking and Bridge Timbers*
- 35 *Golf Course and Bikeway Bridges*
- 36 *Sea Wall and Marine Timbers*
- 37 *Salt Storage Bins and Laminated Timbers*



Lumber and Building Materials

- 38 *Dimensional Lumber*
- 39 *Pole Barn Posts*



Metal Fabrication

- 40-41 *Metal Fabrication*



Hardware

- 42-43 *Fasteners and Screws*
- 44 *Miscellaneous Hardware*



Information

- 45 *Terms and Conditions*
- 46-47 *Frequently Asked Questions*
- 48 *Our Facilities*
- 49 *Index*





Round Fence Posts

As one of the leading manufacturers of round fence posts in North America, our Nacogdoches, Texas mill was one of the first mills in the southern United States to install a system to produce turned posts rather than peeled posts. They are straighter, cleaner and have less bark or unsightly blemishes and by using true Southern Yellow Pine Saplings, they are the strongest posts available.

Stocking Locations - Round Posts

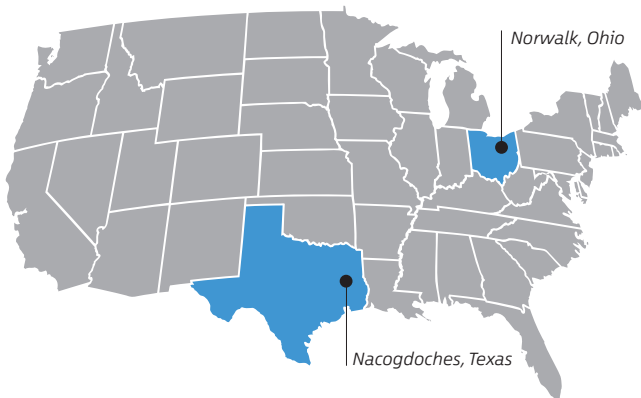

Our posts are then bundled in smaller, square packs with sticks between every row not just to make the pack square but more importantly to allow every post in the bundle to dry more evenly. This drying process assures that the posts will be treated correctly to the American Wood Protection Association Standards with any of our most common preservatives; CCA, CA-C, MCA or Creosote.

Other manufacturers have tried to copy the look of our posts but the strength, treatment and quality of our posts remain unsurpassed. The smaller square bundles have additional benefits like being able to use smaller, standard forklifts and they stack more neatly and efficiently. Then we use cloth banding to make them safer and easier to open without sharp steel strapping.



Smaller, Square Packs



Log Cabin Fence | Amity, Pennsylvania



Sands Fence | Pulaski, Tennessee

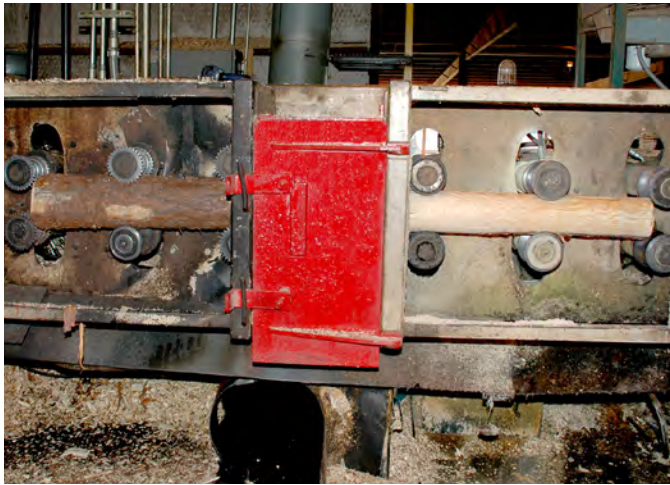

Simpsonville, Kentucky



Sugarcreek, Ohio

Southern Yellow Pine Round Turned Fence Posts

CCA Item #	CA-C Item #	Lbs. ea.	Description
0356601-1202	0356601-1702	18.5 lbs	3 1/2 x 6'6"
0466001-1202	0466001-1702	30.53 lbs	4" x 6'6"
0470001-1202	0470001-1702	32.88 lbs.	4" x 7'
0476001-1202	0476001-1702	35.23 lbs.	4" x 7' 6"
0480001-1202	0480001-1702	37.58 lbs.	4" x 8'
0410001-1302	0410001-1702	46.98 lbs.	4" x 10'
0570001-1202	0570001-1702	51.4 lbs.	5" x 7'
0576001-1202	0576001-1702	55.08 lbs.	5" x 7'6"
0580001-1202	0580001-1702	58.75 lbs.	5" x 8'
0590001-1202	0590001-1702	66.09 lbs.	5" x 9'
0510001-1302	0510001-1702	78.66 lbs.	5" x 10'
0512001-1302	0512001-1702	88.12 lbs.	5" x 12'
0660002-1202	0660002-1702	74.52 lbs.	6" x 6'
0676001-1202	0676001-1702	79.38 lbs.	6" x 7' 6"
0680001-1202	0680001-1702	84.67 lbs.	6" x 8'
0690001-1202	0690001-1702	97.37 lbs.	6" x 9'
0610001-1302	0610001-1702	117.6 lbs.	6" x 10'
0612001-1302	0612001-1702	136.03 lbs.	6" x 12'
0780001-1202	0780001-1702	115.34 lbs.	7" x 8'
0790001-1302	0790001-1702	129.76 lbs.	7" x 9'
0710001-1302	0710001-1702	144.18 lbs.	7" x 10'
0712001-1302	0712001-1702	176.86 lbs.	7" x 12'
0880001-1202	0880001-1702	154.12 lbs.	8" x 8'
0810001-1302	0810001-1702	188.46 lbs.	8" x 10'

+ Also Available in MCA and Cresosote



Sands Fence | Pulaski, Tennessee

2014 06/23 11:07



Round Domed Fence Posts

Adding a dome top to our high quality, Southern Yellow Pine, turned Fence Posts offers an inexpensive alternative to dress up and add character to our posts. We stock both 6 inch and 7 inch domed posts with a 7/8 inch hole to attach our guardrail or run cable through while we also stock a 6 inch post with just the dome top. Dome tops are available on additional sizes of our 5 inch, 6 inch or 7 inch posts as they go through production and before they are treated in order to obtain the best finished look and longevity.



Toledo Zoo | Toledo, Ohio

Pointed Fence Posts

Our Pointed Round Posts make easy work for driving the posts into many soil conditions. Sometimes even a backhoe or loader bucket can be used to just push or pound these posts right into the ground. Pointed posts are available in 4 inch, 5 inch or 6 inch diameters and are made to order requiring additional time to process.

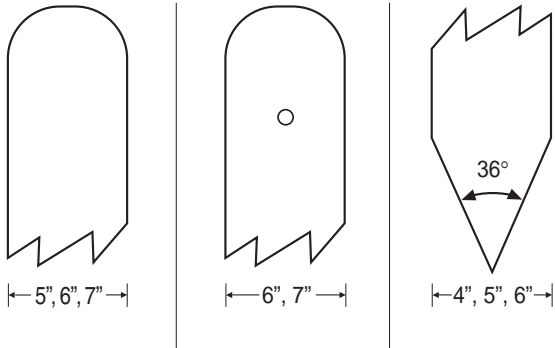

Southern Yellow Pine Turned Dome Top Post

CCA Item #	CA-C Item #	Lbs. ea.	Description
0660002-1206	0660002-1706	63.50 lbs.	6" X 6'

Southern Yellow Pine Round Turned Dome Top Posts with 7/8" Hole

0660002-1205	0660002-1705	63.50 lbs.	6" X 6'
TEX7506-1301	0756001-170F	105.00 lbs.	7 1/2" X 6'

Southern Yellow Pine Round Turned Pointed Tip Posts

0470001-120P	0470001-170P	32.88 lbs.	4" X 7'
0480001-120P	0480001-170P	37.58 lbs.	4" X 8'
0570001-120P	0570001-170P	51.40 lbs.	5" X 7'
0580001-120P	0580001-170P	58.75 lbs.	5" X 8'
0680001-120P	0680001-170P	84.67 lbs.	6" X 8'

+ Also available in MCA and Cresosote



Round Faced Fence Posts

For jobs where a flat surface on a round post is needed to fasten boards, wire or cable, our Round Faced Fence Posts are the perfect solution. We take our quality Round Fence Posts and saw one side flat or "faced" the entire length of the post producing a 3 1/2 inch or 4 inch wide nailing surface on the 5 inch and 6 inch posts respectively.

The sawing is done before treating to get the same long lasting quality of all our wood products. Treatment options include CCA, CA-C, MCA and Creosote.

We stock these in both 5 inch and 6 inch diameter posts in 7 1/2 feet lengths but additional sizes and lengths are also available.

Southern Yellow Pine Round Turned Faced Fence Posts

CCA Item #	CA-C Item #	Lbs. ea.	Description
0576001-1207	0576001-1707	47.70 lbs.	5" X 7' 6"
0580001-1207	0580001-1707	53.13 lbs.	5" X 8'
0676001-1207	0676001-1707	72.90 lbs.	6" X 7' 6"
0680001-1207	0680001-1707	77.67 lbs.	6" X 8'

+ Also available in MCA and Cresosote

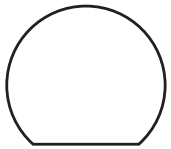

← 3-1/2" →

← 5" →

Top View

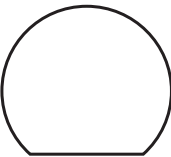

← 4" →

← 6" →

Top View



New Albany, Ohio



Penrod Fence | Simpsonville, Kentucky





Board Fencing

Our agricultural board-on-board fencing, also known as "Kentucky Board Fence" is cut for strength and longevity at 6 inches wide, 1-1/8 inch thick and in 16 foot lengths designed for 8 foot post spacing. We stock them in Southern Yellow Pine or Yellow Poplar. Oak boards are available on a special order basis.



Southern Yellow Pine

Our southern yellow pine boards are stocked treated with environmentally friendly CA-C for above ground use. Southern Yellow Pine allows the chemical to penetrate deeper into the wood for a long service life and are 30% stronger than Oak Boards and nearly twice as strong as the Poplar



Boards.

Yellow Poplar

Our yellow poplar considered a soft hardwood, are also stocked and treated with environmentally friendly CA-C but they will only accept a small amount of treatment.

1" X 6" - 16' Fence Boards

Item #	Lbs. ea.	Description
0106162-1701	38.40 lbs.	1" X 6" - 16' SYP Rough Full Sawn Fence Board .15 CA-C
0106162-7701	40.00 lbs.	1" X 6" - 16' Poplar Rough Full Sawn Fence Board .15 CA-C To Refusal

+ Also available in MCA



LTJ Enterprises | Wonderlake, Illinois



John-Eric Anderson | Brooklyn, Wisconsin



5 Star Round Rail Fencing

5 Star Round Rail Fencing is available in 2-rail or 3-rail versions using our 4 inch diameter Turned Southern Yellow Pine Posts offering a beautiful, uniform, finished look. The tops of our 6 foot or 7 foot posts are chamfered and the 8 foot rails are doweled and chamfered at the ends.

Our pre-assembled, matching, heavy duty gates are available as 48 inch or 60 inch wide in both 2-rail and 3-rail styles great for walk through areas or hang 2 gates to double the opening for vehicle access. The round uprights have chamfered tops with doweled rails, and for additional strength we add cross-bracing and bolts.

With the strength of Southern Yellow Pine and environmentally friendly preservatives of CA-C or MCA treatments, the long lasting life and beauty of our round rail cannot be beat compared to plastic or other fencing.

Round Rail Fencing

Item #	Lbs. Ea	Description
Round Rail Rails		
048000R-R706	37.58 lbs.	8' SYP Rail Dowelled .15 CA-C
Round Rail 4" x 6" 2 Hole Posts		
046000R-R706	31.32 lbs.	2 Hole SYP Line Post .15 CA-C
046000R-R707	31.32 lbs.	2 Hole SYP End Post .15 CA-C
046000R-R709	31.32 lbs.	2 Hole SYP Corner Post .15 CA-C
Round Rail 4" x 7" 3 Hole Posts		
047000R-R706	36.54 lbs.	3 Hole SYP Line Post .15 CA-C
047000R-R707	36.54 lbs.	3 Hole SYP End Post .15 CA-C
047000R-R709	36.54 lbs.	3 Hole SYP Corner Post .15 CA-C
Round Rail Gates		
046000R-R704	81.85 lbs.	48" 2 Rail SYP Gate .15 CA-C
046000R-R705	93.95 lbs.	60" 2 Rail SYP Gate .15 CA-C
047000R-R704	92.05 lbs.	48" 3 Rail SYP Gate .15 CA-C
047000R-R705	107.20 lbs.	60" 3 Rail SYP Gate .15 CA-C
Gate Hardware		
50LL000-1000	1.05 lbs.	Gate Loop Latch
50124EH-1100	1.22 lbs.	Screw Hook & Eye Hinge 1/2" X 4"
50DR24B-1000	2.25 lbs.	24" Cane Bolt (Drop Rod)

+ Also available in MCA



Pre-Assembled Gates

SEE PAGE 44 FOR HARDWARE



Brian Mastro | Potomac, Maryland



Gill Landscape | Corpus Christi, Texas

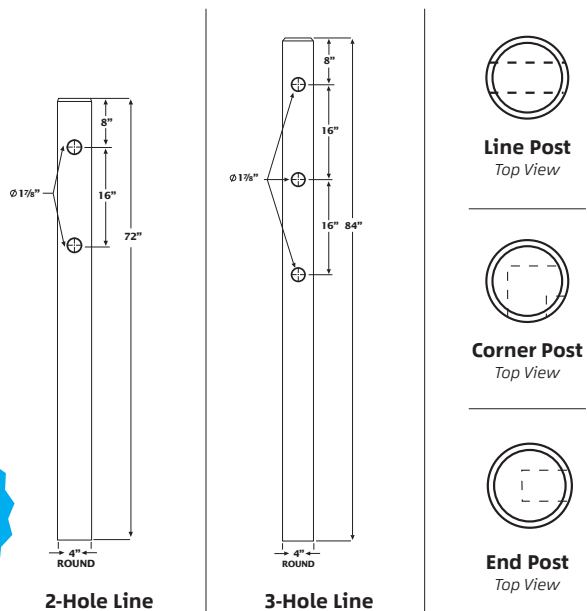



Our Split Rail Fencing is made from top quality southern yellow pine and treated with an environmentally friendly preservative.



King Fence, Temperance, Michigan



Jack McCray | Albion, Indiana



She-an-I-Fence, Woodstock, IL

Made to appear rustic, our 5 Star Split Rail Fencing is the simplest to install. Just set the posts at approximately 10' 4" spacing and the tapered ends on the rails makes it easy to slip the rails into place. Both 2-rail and 3-rail versions are available and the rails are 11' so the tapered ends will overlap.

The environmentally friendly CA-C or MCA preservatives will penetrate through the Southern Yellow Pine posts and rails for increased longevity lasting decades longer than our competitors.

Our posts and rails are designed to easily attach wire fencing to prevent pets from escaping and rodents from entering by having one side cut with a flat edge.

Fully Treated with CA-C or MCA

11' Rails Low Cost Fencing

Flat Nailable Rail Surface for Ease of Attaching Wire Fencing

High Quality Gates

Easy to Handle with Stackable Bundles

Ready to Ship

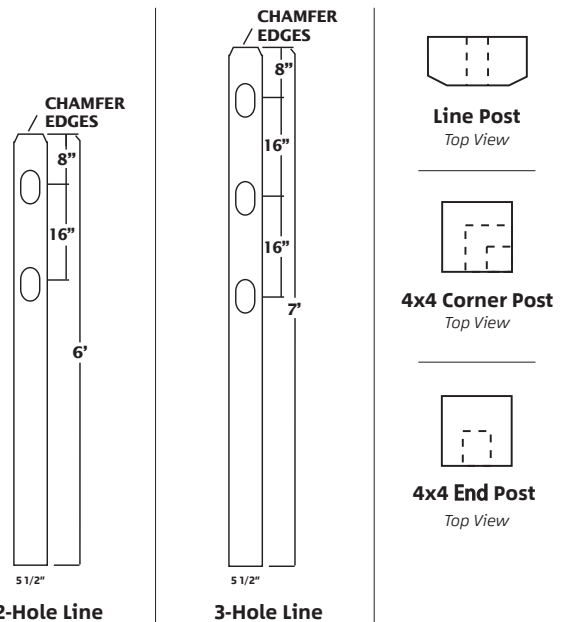



Pre-Assembled Gates

Very solid, matching, pre-assembled gates complete the fence. The round uprights are chamfered at the top and mortised for the rails which are bolted and then cross bracing is added for even more stability. They are available as 48 inch or 60 inch wide in both 2-rail and 3-rail styles great for walk through areas or hang 2 gates to double the opening for vehicle entranceways.



Split Rail Fencing

Item #	Lbs. ea.	Description
Split Rail • Rail		
0404111-1701	41.62 lbs.	11' SYP RAIL .15 CA-C
Split Rail 3" x 6" - 6' • 2 Hole Posts		
0306061-1706	33.00 lbs.	2 Hole Line Post .15 CA-C
0404061-1707	38.40 lbs.	2 Hole End Post .15 CA-C
0404061-1709	38.40 lbs.	2 Hole Corner Post .15 CA-C
Split Rail 3" x 6" - 7' • 3 Hole Posts		
0306071-1706	38.50 lbs.	3 Hole Line Post .15 CA-C
0404071-1707	44.80 lbs.	3 Hole End Post .15 CA-C
0404071-1709	44.80 lbs.	3 Hole Corner Post .15 CA-C
Split Rail 3" x 6" - 7' • 3 Hole Posts		
0306071-1706	38.50 lbs.	3 Hole Line Post .15 CA-C
0404071-1707	44.80 lbs.	3 Hole End Post .15 CA-C
0404071-1709	44.80 lbs.	3 Hole Corner Post .15 CA-C
Split Rail 3" x 6" - 7' • Gates		
0306061-1704	66.20 lbs.	48" 2 Rail SYP Gate .15 CA-C
0306061-1705	80.50 lbs.	60" 2 Rail SYP Gate .15 CA-C
0306071-1704	90.10 lbs.	48" 3 Rail SYP Gate .15 CA-C
0306071-1705	105.05 lbs.	60" 3 Rail SYP Gate .15 CA-C
Gate Hardware		
50LL000-1000	1.05 lbs.	Gate Loop Latch
50124EH-1100	1.22 lbs.	Screw Hook & Eye Hinge 1/2" X 4"
50DR24B-1000	2.25 lbs.	24" Cane Bolt (Drop Rod)

Snake Rail Fencing

The Snake Rail Fencing zigzags each section and the rail ends overlap recreating the look of early forms of fencing as seen in American historical photographs and paintings. The eleven foot long rails are the same as our regular split rail with the ends taper cut, except that we also offer the rails without the taper cut ends.

Most installations have a finished height between 30 and 45 inches (6-9 rails high) and since the ends overlap and the sections zigzag, each 11 foot section typically covers an estimated 7 feet of run. To add stability, particularly for taller fences or if people may climb or sit on the fence, a post or angle bracing can be used at each junction or just fasten each successive rail to the lower rail with a screw.

Made from Southern Yellow Pine posts and treated with CA-C or MCA for years of life so as the rails age and grey, they will take you back in time resembling the look of the Early American fence.



Snake Rail Fencing

Item #	Lbs. Ea	Description
0404111-1606	41.62 lbs.	11' SYP Snake Rail .06 CA-C - Non Tapered Ends
0404111-1601	41.62 lbs.	11' SYP Rail .06 CA-C - Tapered Ends

+ Also available in MCA





Wood Piling

We bring the same higher standards of treating our fencing and highway products to treating our Southern Yellow Pine Pilings and Poles with the same objective: to achieve the longest service life possible. Our standard CCA piling treatment of .60 lbs. per cubic foot works great even in fresh water applications, but we also treat our piling to higher chemical retentions for jobs such as salt water installations per the American Wood Protection Association (AWPA) Standards of CCA, CA-C, MCA, Creosote and Pentachlorophenol.

Pilings are available in 8' to 40' lengths for most treatment options and in diameters of an 8" tip or anywhere from an 8" butt to a 12" butt.

Southern Yellow Pine Round Piling .60 CCA

	8" Butt	9" Butt	10" Butt	12" Butt	8" Tip
8'	●				
10'	●	●			
12'	●	●			
14'	●	●			
16'	●	●	●		
18'	●	●	●		
20'	●	●	●	●	●
25'	●	●	●	●	●
30'	●	●	●	●	●
35'			●	●	●
40'			●	●	●

● Available

Our wood piling and utility poles are great solutions for:

- Light poles
- Barn poles
- Beach homes
- Resorts
- Restaurants
- Hops farms
- Zip line courses
- Vineyards
- Obstacle courses

Hanging netting to protect people and property from:

- Golf courses
- Driving ranges
- Paintball
- Baseball fields as well as litter.



Bay View, Ohio



Rietschlin Construction | Howard, Ohio



Utility Poles

Utility Poles are stocked in several classes in our Norwalk, OH location with lengths up to 60' (see chart) treated with .60 CCA for many common uses. While we have continued to expand our stock supply, we can also supply your need for CA-C, MCA, Pentachlorophenol or Creosote treated poles.

Smaller tapered pole sizes are also available from 14' to 20' lengths and diameters. These are shorter than the length of a utility pole and not as thick as a piling for when that heavy duty pole is more than necessary.



Side Branding



Butt Branding



Barn Poles

Item #	Lbs. Ea	Description
0516002-1302	142.56 lbs.	5"x16' SYP Round Tapered Poles .60 CCA
0616002-1302	220.80 lbs.	6"x16' SYP Round Tapered Poles .60 CCA
0518002-1302	160.38 lbs.	5"x18' SYP Round Tapered Poles .60 CCA
0618002-1302	268.92 lbs.	6"x18' SYP Round Tapered Poles .60 CCA
0520002-1302	235.20 lbs.	5"x20' SYP Round Tapered Poles .60 CCA
0620002-1302	320.40 lbs.	6"x20' SYP Round Tapered Poles .60 CCA
0525002-1302	319.50 lbs.	5"x25' SYP Round Tapered Poles .60 CCA
0625002-13T2	430.50 lbs.	6"x25' SYP Round Tapered Poles .60 CCA

25'- 60' Southern Yellow Pine Round Poles Unframed .60 CCA

Class	Min. Tip Dia.	25'	30'	35'	40'	45'	50'	55'	60'
1	8.9"	●	●	●	●	●	●	●	●
2	7.8"	●	●	●	●	●	●	●	●
3	7.25"	●	●	●	●	●	●	●	●
4	6.2"	●	●	●	●	●	●	●	●
5	5.9"	●	●	●	●	●	●	●	●
7	4.7"	●	●	●	●	●	●	●	●
9	4.7"	●	●	●	●	●	●	●	●

● Available ● Stock

Average diameter increases 1" for every 10' from tip to butt.





No Taper Poles

Our "No Taper Poles" are great for projects that require a more finished look or when a uniform, straight from top to bottom pole is needed. These poles are made to order, turned from Southern Yellow Pine for strength and are great for interior use or treated for exterior use. Often used for log cabins, columns, beams, rafters, trellises or railings.

These made to order poles are great for projects that require a more finished look.

No Taper Poles are available in diameters up to 18 inches and in lengths up to 28 feet but are not stocked so additional time to produce and dry is required.



Cleveland Metroparks Zoo | Cleveland, Ohio



KF Ventures | Port Clinton, Ohio





Ranch Entrance Timber Kits



Saddle Cut Top

Create the ultimate entrance with a Ranch Entrance Timber Kit using our No Taper Poles and adding a custom designed Entrance Sign made from wood or steel.

With many options to choose from, our basic Heavy Duty Kit sits the cross pole in a saddle cut on both upright poles with long, heavy duty structural screws to secure the cross timber in place.

Our Super Duty Kits come with steel mounting brackets for extra holding power and are offered with an optional Double Cross Pole for a great looking structure to mount our custom made signs.

Heavy Duty - Ranch Entrance Timber Kits .60 CCA

Cross Pole	10" x 24' Upright Poles	
	Item #	Lbs. Ea
12" x 16'	RE10241-1306	2,257 lbs
12" x 20'	RE10241-2300	2,545 lbs
12" x 24'	RE10241-2304	2,833 lbs

Super Duty - Ranch Entrance Timber Kits .60 CCA

Cross Pole	12" x 21' Upright Poles	
	Item #	Lbs. Ea
12" x 24'	RE12211-2304	3,171 lbs
12" x 28'	RE12211-2308	3,623 lbs

Super Duty - Ranch Entrance Timber Kits .60 CCA

Double Cross Pole	12" x 24' Upright Poles	
	Item #	Lbs. Ea
12" x 28'	RE12241-238D	6,024 lbs

Wood Entrance Signs

- CNC routed wood signs
- Hand painted letters and logos
- Custom shapes and sizes on one or two sides

Steel Entrance Signs

- Plasma cut and powder coated in many colors
- Custom plasma cut with any design or logo
- A588 weathering steel or powder coated in many colors

Custom Made Signs

Our custom designed signs create a unique look with CNC routed wood or plasma cut steel that look great hanging from our Ranch Entrance Timber Kits.

The CNC Routed Wood signs start with laminating our Southern Yellow Pine treated lumber into panels up to 4 feet high and 12 feet long. Our creative design team then routes custom logos, designs or lettering using a CNC on one side or both front and back then hand painting them.

The Plasma Cut Steel signs are cut from A588 Weathering Steel or Powder Coated in many color options with nearly any design or logo.



■ Linesville, Pennsylvania



■ Middletown, New Jersey



■ Mt. Pleasant, Texas



Round Bollards

Our Texas grown Southern Yellow Pine on our rounder system turns the best looking, clean and uniform round wood bollards anywhere. Customized with decorative tops or drilled holes to allow rope or cable to pass through are common choices. Then we treat to .15 CA-C for environmentally friendly protection for decades.

Great for parking lots, bike paths, buildings and anywhere you want to prevent vehicles from driving through. Add rope or chain strung between each post to discourage pedestrian traffic if needed.

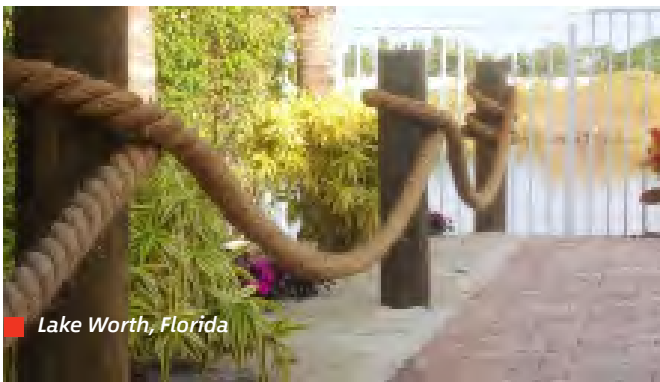

Lake Worth, Florida

Dockside Kits

By grouping 3 like styles of different size bollards and wrapping them with rope, offers an attractive and functional barrier that is especially popular in nautical settings. Choose one of our styles or create your own.



Sandusky, Ohio

Dockside Kits

Item #	Lbs. ea.	Description
046DOCK-170D	103.36 lbs.	4" Dockside - 3 posts with rope kit
056DOCK-170D	125.00 lbs.	5" Dockside - 3 posts with rope kit
066DOCK-170D	232.84 lbs.	6" Dockside - 3 posts with rope kit
076DOCK-170D	389.73 lbs.	7" Dockside - 3 posts with rope kit

Standard Round Bollards

Description	4" Tip x 6'	5" Tip x 6'	6" Tip x 6'	7" Tip x 6'
A SYP Round Turned w/Chamfer Top .15 CA-C	0460001-170A	0560001-170A	0660001-170A	0760001-170A
B SYP Round Turned w/Chamfer Top/1 Groove .15 CA-C	0460001-170B	0560001-170B	0660001-170B	0760001-170B
C SYP Round Turned w/Dome Top .15 CA-C		0560001-170C	0660001-170C	0760001-170C
D SYP Round Turned w/Beveled Top .15 CA-C	0460001-170D	0560001-170D	0660001-170D	0760001-170D
E SYP Round Turned .15 CA-C	0460001-1702	0560001-1702	0660001-1702	0760001-1702
lbs. ea.	28.19 lbs.	44.06 lbs.	63.50 lbs.	86.50 lbs.

Round Bollards

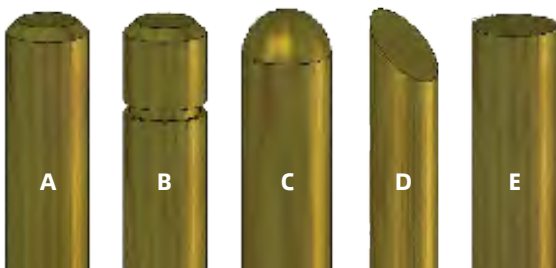

Eagle Creek Golf Course
Norwalk, Ohio

See page 44 for rope and chain options



Square Bollards

Square Wood Bollards are another great option to line parking lots, bike paths, buildings or anywhere you want to prevent vehicles for pedestrian safety. If you need a barrier to discourage pedestrians from crossing as well, then add rope and chain strung between each post.

Our standard square bollards are planed from Southern Yellow Pine wood on all four sides (S4S) in order to provide a great looking, clean and uniform bollard. Add decorative chamfering, grooves, slanted top or pyramid top to create an attractive look to fit your needs. We then pressure treat them with environmentally friendly .15 CA-C to last for decades.

Square Bollards

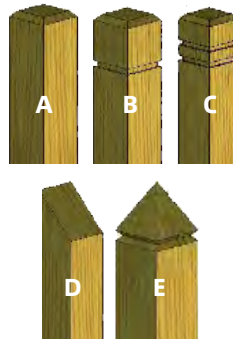

Standard Square Bollards

Surfaced Four Sides (S4S)

Rough Sawn

Description	Surfaced Four Sides (S4S)			Rough Sawn	
	4" X 4" - 6'	6" X 6" - 6'	8" X 8" - 6'	10" X 10" - 6'	12" X 12" - 6'
A #2 SYP w/Chamfer Top .15 CA-C	0404062-170A	0606062-170A	0808062-170A	1010062-170A	1212062-170A
B #2 SYP w/Chamfer Top/1 Groove .15 CA-C	0404062-170B	0606062-170B	0808062-170B	1010062-170B	1212062-170B
C #2 SYP w/Chamfer Top/2 Grooves .15 CA-C	0404062-170C	0606062-170C	0808062-170C	1010062-170C	1212062-170C
D #2 SYP w/ Bevel Top .15 CA-C	0404062-170D	0606062-170D	0808062-170D	1010062-170D	1212062-170D
E #2 SYP w/Pyramid Top/1 V-Groove .15 CA-C	0404062-170E	0606062-170E	0808062-170E	1010062-170E	1212062-170E
Lbs. ea.	30.40 lbs.	68.40 lbs.	121.60 lbs.	240.00 lbs.	345.60 lbs.

Collapsible and Removable Bollards

American Timber and Steel offers a collapsible or a removable bollard in order to allow access by some vehicles like maintenance and emergency while keeping other traffic out.

The Collapsible Bollard Kit comes with the galvanized steel base welded to a strong anchor assembly which slips into fresh concrete for ease in installation. When set, attach the wood pieces and fold them up to create a barrier which is lockable to avoid unauthorized access. When the wood pieces are unlocked and unfolded, only a 3" clearance is needed to gain access. Another version available can be bolted down instead of set in concrete.

The Removable Bollard Kit comes with a stainless steel base with two hinged sides in which the wood bollard fits between and is held in place by lockable bolts to create a barrier or remove the bolts and fold down the sides to release the bollard and allow access. With the wood removed, the stainless steel base is the only piece still on the ground with less than an inch of clearance making it much less obtrusive. This kit is designed to be set in concrete but can also be made to be bolted down instead.

Collapsible and Removable Bollards

Item #	Lbs. ea.	Description
060826C-B706	60.00 lbs.	A Collapsible bollard CA-C w/hardware kit
50CBSHO-110A	18.75 lbs.	B Collapsible bollard anchor plate hardware only
ATSBOLA-KIT	56.50 lbs.	C Removable SS bollard CA-C w/hardware kit
ATSBOLA-370K	20.00 lbs.	D Removable bollard anchor assembly hardware only



Collapsible Bollard



Collapsible Anchor Assembly



Removable Bollard



Removable Anchor Assembly



Mortised and Notched Post & Rail

Mortised Post and Rail Systems and Notched Post and Rail Systems are two of American Timber and Steel's biggest customized specialties for uses in parking lots, along driveways, parks and condominium complexes in nearly any design imagined.

The Mortised System has the rail going through the center of the posts without any necessary fasteners whereas the Notched System has a section cut out from one side of the posts to allow the rail to set inside and attach with carriage bolts. Another option is to attach the rail to uncut (flat) posts using longer carriage bolts to secure the rail in place.

Our Standard Post and Rail Systems are of an 8x8 chamfered post with 4x8 rails or a 12x12 chamfered post with 5x8 rails. Using our Texas grown Southern Yellow Pine, we chamfer the tops of the rough sawn posts and plane down the rails for a smoother, cleaner finish. But a custom design is requested most often with unlimited choices of post sizes, a single rail or multi-rail system and by creating decorative tops like chamfered, roofed, pyramid, grooved, slanted or a whole new design of your own.

Typical post sizes range from 4x4 through 12x12 and the rails from 1x4 through 6x12 however we can accommodate larger sizes upon request as well as smooth or rough sawn finish options. While using Southern Yellow Pine for its strength and ability to accept chemicals deep into the wood during treatment is most popular, many other species are available as well. Then choose your treatment of environmentally friendly CA-C or MCA as the choice for any installation where people may be in contact or other treatments like CCA can be used along roadways.



Mortised Rail
Maryland Renaissance Festival
Annapolis, Maryland

8" X 8" Standard Mortised/Notched Post & Rail Systems

Item #	Lbs. ea.	Description	Bolts Required
0808542-1X05	128.00 lbs.	8"X8" - 5' 4" #2 SYP Rough Sawn w/Chamfer Top Mortised End Post Treated	N/A
0808542-1X06	128.00 lbs.	8"X8" - 5' 4" #2 SYP Rough Sawn w/Chamfer Top Mortised Line Post Treated	N/A
0808542-1X07	128.00 lbs.	8"X8" - 5' 4" #2 SYP Rough Sawn w/Chamfer Top Mortised Corner Post Treated	N/A
0808542-1X08	128.00 lbs.	8"X8" - 5' 4" #2 SYP Rough Sawn w/Chamfer Top Notched Line Post Treated	5/8" X 8"
0808542-1X09	128.00 lbs.	8"X8" - 5' 4" #2 SYP Rough Sawn w/Chamfer Top Blank Post Treated	5/8" X 12"
0408082-1X00	96.00 lbs.	4"X8" - 8' #2 SYP Smooth 4 Sides Rail Treated	
0408102-1X00	120.00 lbs.	4"X8" - 10' #2 SYP Smooth 4 Sides Rail Treated	

SEE PAGES 42-43 FOR HARDWARE

12" X 12" Standard Mortised/Notched Post & Rail Systems

Item #	Lbs. ea.	Description	Bolts Required
1212062-1X05	258.20 lbs.	12"X12" - 6' #2 SYP Rough Sawn W/Chamfer Top Mortised End Post Treated	N/A
1212062-1X06	258.20 lbs.	12"X12" - 6' #2 SYP Rough Sawn W/Chamfer Top Mortised Line Post Treated	N/A
1212062-1X07	258.20 lbs.	12"X12" - 6' #2 SYP Rough Sawn W/Chamfer Top Mortised Corner Post Treated	N/A
1212062-1X08	258.20 lbs.	12"X12" - 6' #2 SYP Rough Sawn W/Chamfer Top Notched Line Post Treated	5/8" X 12"
1212062-1X09	258.20 lbs.	12"X12" - 6' #2 SYP Rough Sawn W/Chamfer Top Blank Post Treated	5/8" X 16"
0508082-1X00	101.35 lbs.	5"X8" - 8' #2 SYP Smooth 4 Sides Rail Treated	
0508102-1X00	126.65 lbs.	5"X8" - 10' #2 SYP Smooth 4 Sides Rail Treated	

SEE PAGES 42-43 FOR HARDWARE



Blank Rail | Croton Falls, New York



Blank Rail | Chagrin Falls, Ohio



Mortised Rail | Norwalk, Ohio



Notched Rail | East Manchester Township Pennsylvania



Mortised Rail | Norwalk, Ohio

Standard Post and Rail Systems



Mortised



Notched



Blank



Square American Timber Rail

We designed our American Timber Rail as a cost effective solution for jobs that do not need the strength of our Steel-Backed Timber Guardrail yet it looks great and offers protection around areas like parking lots, pathways and in parks. This easy to assemble guide rail system has 6 foot on center post spacing and 12 foot splicing.

Using surfaced Southern Yellow Pine for a uniform look and reliable strength, we chamfer the 6 inch by 8 inch post tops and the face of the 4 inch by 8 inch rails for an attractive finish and all the plates and hardware are made from weathering steel for a rustic appeal. Then to make sure we get the longest life, we treat it to .60 with CCA



Dickerson Fence | Durham, North Carolina

Square American Timber Rail - 6" x 8" - 6' Posts with 4" x 8" - 12'Rails

Item #	Lbs. ea.	Description
ATS6841-2301	315 lbs.	12' Section - Includes: (2) Posts, (1) Rail and Hardware
ATS6841-2302	417 lbs.	Starting & Ending Kit - Includes: (3) Posts, (2) 7' Rails and Hardware

+ Also available in CA-C and MCA

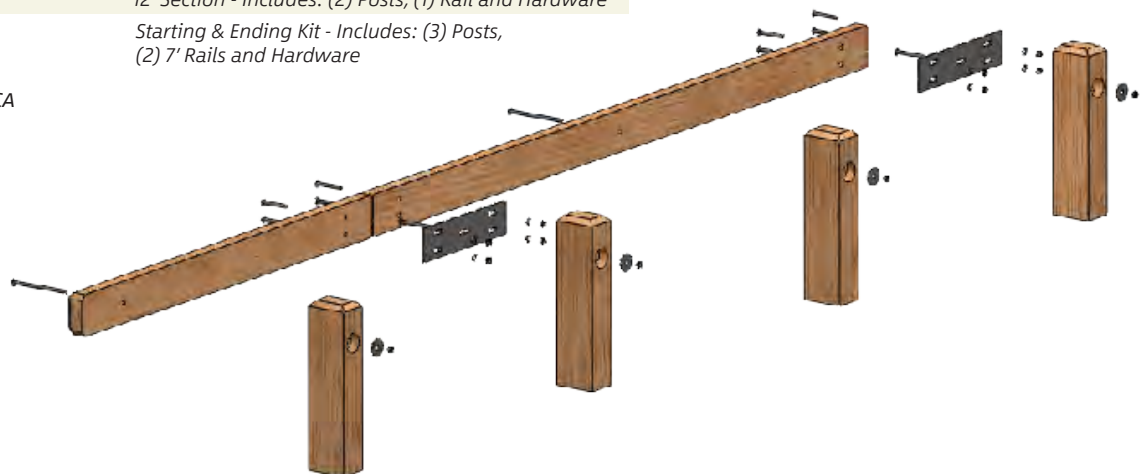



Round American Timber Rail

Our Round American Timber Rail was designed for an even more rustic look than the Square American Timber Rail for jobs that do not need the full strength of our Round Steel-Backed Timber Guardrail yet looks great and offers the protection needed.

The dome top on our 7 inch round posts offer an attractive finish while the Southern Yellow Pine offers reliable strength. Then for an added rustic appeal all the plates and hardware are made from weathering steel. The trimmed flat edge on the back of the 7 inch by 12 foot rail helps to assemble the guide rail using the same 6 foot on center post spacing and 12 foot splicing as our square system.



Round American Timber Rail - 7" - 6'3" Dome Top Posts with 7" x 12' Rail

Item #	Lbs. ea.	Description
ATS7671-2301	420 lbs.	12' Section - Includes: (2) Posts, (1) Rail and Hardware
ATS7671-2302	555 lbs.	Starting & Ending Kit - Includes: (3) Posts, (2) 7' Rails and Hardware

+ Also available in CA-C and MCA

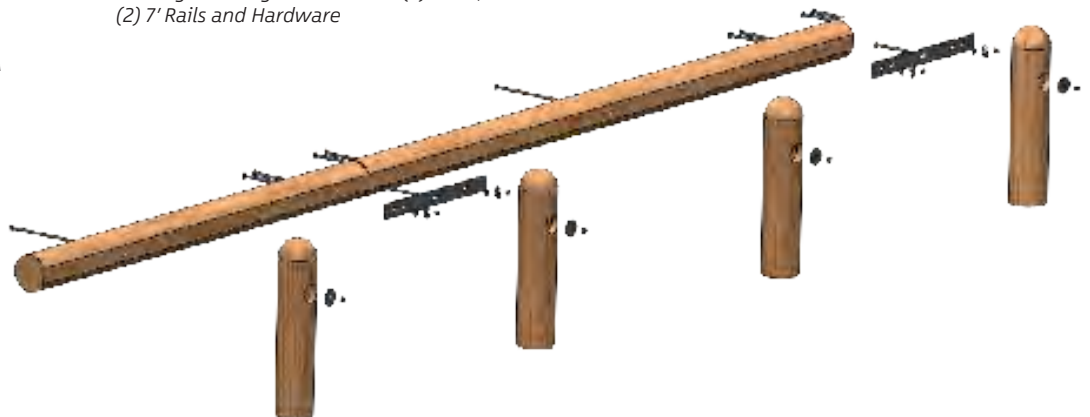



Log Rail

Another easy to install solution to create an attractive, free flowing barrier is our Log Rail that is designed to offer safety as a railing or to offer a comfortable seat. The saddle cut top posts makes installation a breeze by burying the 5 foot posts about 3 feet deep, place the rails snugly on top and fasten with our heavy duty structural screws. Only installations around curves will need the rail ends trimmed for a perfect fit.

Our standard sizes range from a 6 inch to a 12 inch diameter rail with the posts made slightly smaller. The Southern Yellow Pine posts and rails are "turned" giving them a smoother finish then treated with environmentally friendly CA-C preservative to last for decades.



Huron, Ohio



Huron, Ohio

Log Rail Systems

Item	Item #	Lbs. ea.	Description
6" Log Rail	0550001-170S	47.00 lbs.	5" X 5' SYP Round Log Rail Post W/Saddle Top .15 CA-C
	0680001-170T	90.31 lbs.	6" X 8' SYP Round Log Rail - Rail .15 CA-C
8" Log Rail	0650001-170S	58.80 lbs.	6" X 5' SYP Round Log Rail Post W/Saddle Top .15 CA-C
	0880001-170T	150.77 lbs.	8" X 8' SYP Round Log Rail - Rail .15 CA-C
10" Log Rail	0850001-170S	94.23 lbs.	8" X 5' SYP Round Log Rail Post W/Saddle Top .15 CA-C
	1080001-170T	235.44 lbs.	10" X 8' SYP Round Log Rail - Rail .15 CA-C
12" Log Rail	1050001-170S	147.15 lbs.	10" X 5' SYP Round Log Rail Post W/Saddle Top .15 CA-C
	1280001-170T	339.12 lbs.	12" X 8' SYP Round Log Rail - Rail .15 CA-C





Merritt Parkway Guardrail

The Merritt Parkway Guardrail was designed originally for the Merritt Parkway in Connecticut to provide for the safety of modern highways and add beauty to the landscape. Similar to our Steel-Backed Timber System except the Merritt Parkway posts are steel and the wood rails are larger. All components are designed to meet Federal Highway Administration Standards.

The Merritt Parkway was the first "Parkway" in the United States. When a new highway was proposed in the 1920's to ease congestion, there was strong local opposition to "allowing those New Yorkers to invade their property and cut through their estates". Congressman Merritt recommended construction of a "beautiful parkway" which "is not wholly or primarily a means for quick transit, but it should be constructed so as to add beauty to the landscape, and therefore attract desirable residents."



Merritt Parkway | Greenwich, Connecticut



Merritt Parkway | Greenwich, Connecticut

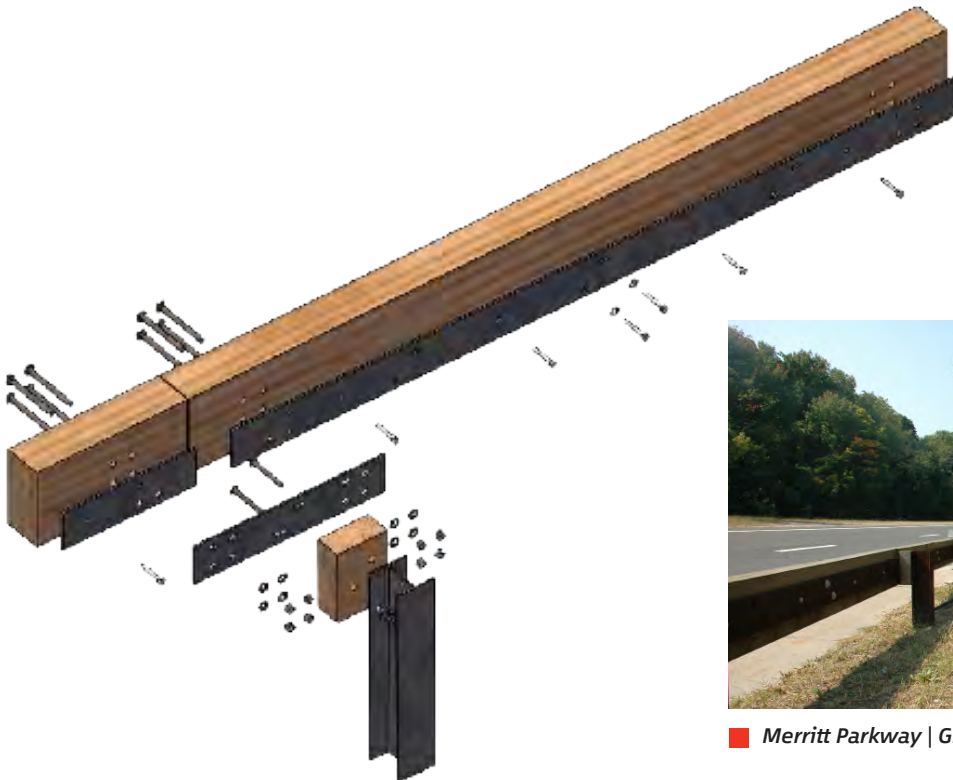

Merritt Parkway | Greenwich, Connecticut



Steel-Backed Timber and Steel-Backed Log Rail

Our Steel-Backed Timber and Log Guardrail systems are not only beautiful but they have been designed for rugged highway use, crash tested and they meet Federal Highway Administration (FHWA) approval. The Square Steel-Backed Timber also has a TL-2 end terminal system available for another safety feature.

Hidden behind each rail spans a steel plate with matching splice plates and steel hardware in either galvanized or

corten (A588 weathering steel). The system is produced using large solid Southern Yellow Pine timbers for a sawn look or logs for a rounded look and has the steel rail plate pre-attached for ease of installation.

This system is very popular along scenic roadways across the country. The wood is treated to .60 CCA and can be left to weather naturally or may be stained or painted to match its surroundings.



Rocky Mountain National Park



Muirfield Village Golf Course
Dublin, Ohio

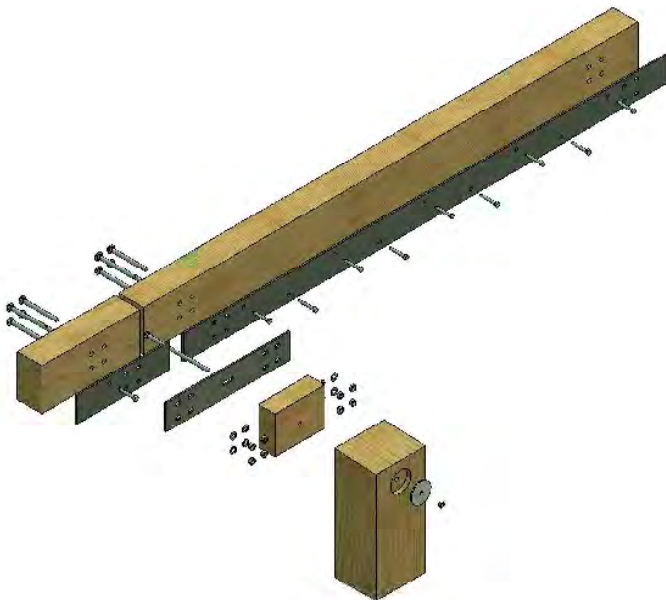

Steamboat, Colorado

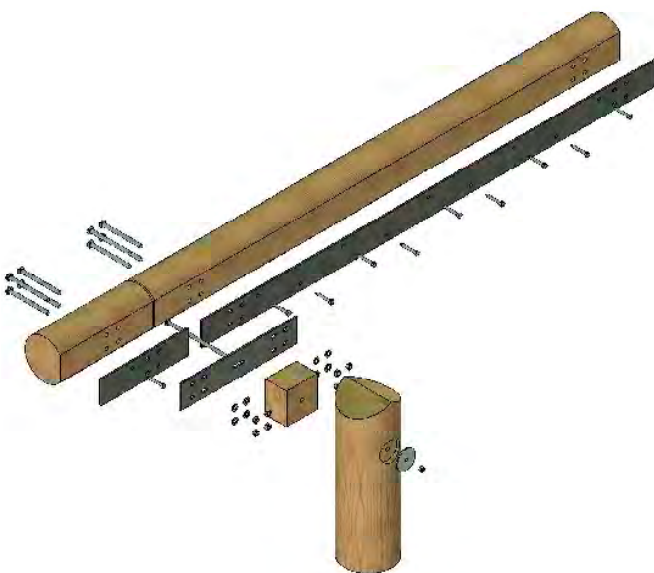



Wood Guardrail Posts and Blocks

As the leading manufacturer of wood guardrail posts in North America and stocking locations across the US, our state of the art manufacturing facilities are able to produce nearly all post and block specifications from Federal to State requirements even though they vary significantly.

Southern Yellow Pine is primarily used which meets AASHTO M-168 for the physical and strength characteristics. Our primary CCA treatment complies with the requirements of AASHTO M-133 preservations as well and we can offer other treatments like, CA-C, Creosote, Pentachlorophenol or nearly any other AWWA, FHWA and state specifications that may be required.

Quality control testing on treatment is constant at ATS to provide required certifications and documentations necessary for projects across America. As members of the American Traffic Safety Association, we have even gone to lengths of developing our own full scale pendulum crash test facility to analyze our new products for safety and effectiveness.

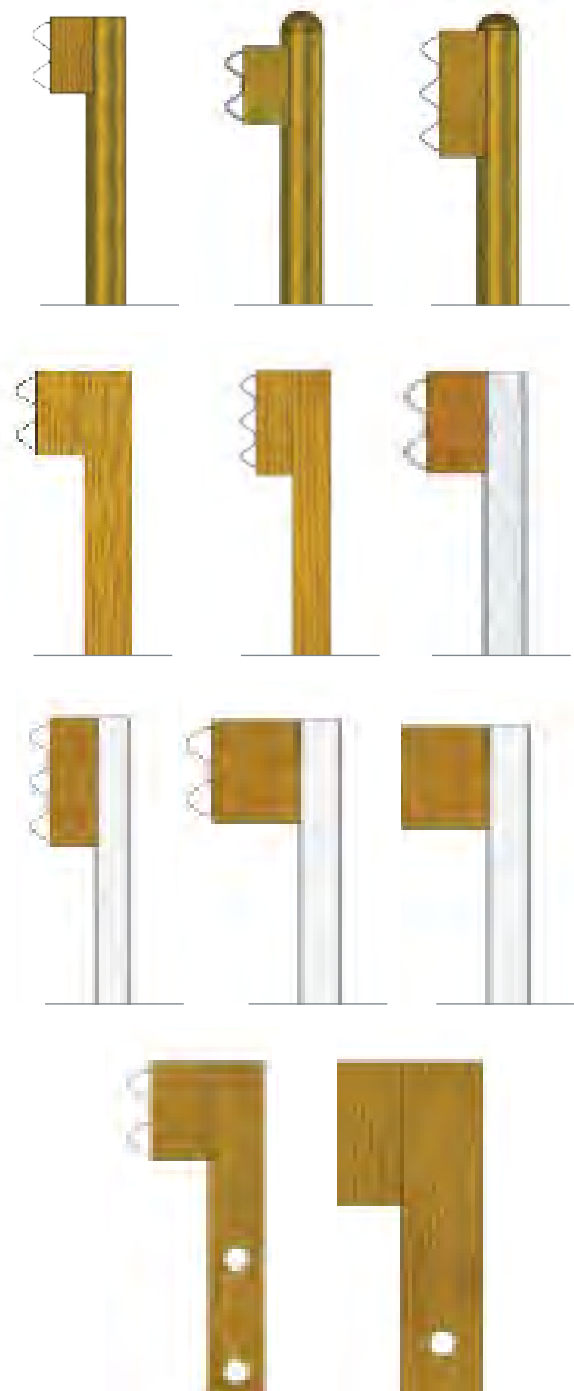



State Spec Wood Product Availability

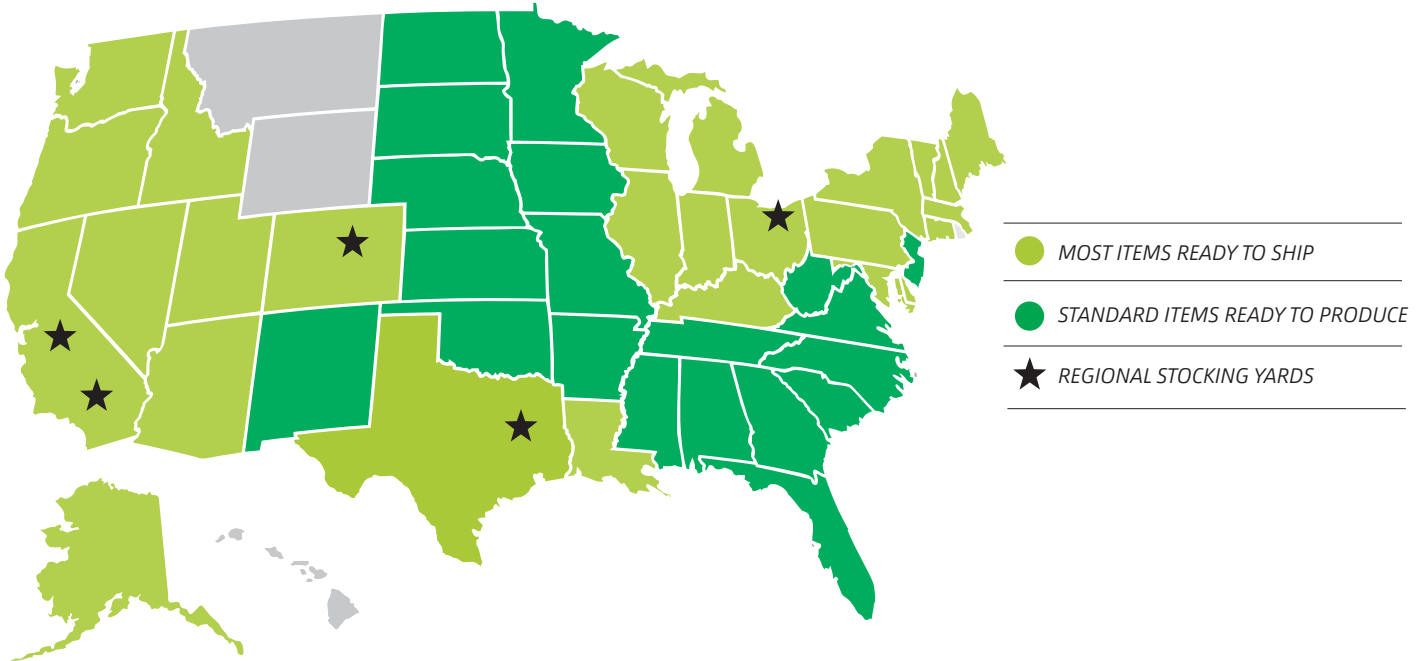



Steel Guardrail Components

In addition to our wood products, American Timber and Steel carries a full line of steel guardrail and all the hardware and fasteners needed to complete guardrail system installations.

We handle 10 Ga. and 12 Ga. Galvanized, as well as, weathering Corten Steel Guardrail and end treatment terminals. All of our Steel Guardrail Components are made in America and they pass all Department of Transportation Standard Specifications.





Domestic Steel Guardrail Components

Item #	Lbs. Ea.	Description
A FHWB250-0200	179.00 lbs.	25' Galv. W-Beam Guardrail 6' 3" Post Spacing
B FHWB126-0200	92.00 lbs.	12' 6" Galv. W-Beam Guardrail 6' 3" Post Spacing
C FHTB126-0200	145.00 lbs.	12' 6" Galv. Thrie-Beam Guardrail
D FHWB126-0400	92.00 lbs.	12' 6" 12 Ga. Corten W-Beam Guardrail 6' 3" Post Spacing
E FHWBHW1-0200	23.00 lbs.	Galv. W-Beam Guardrail Half Wrap End
F FHWBFW1-0200	42.00 lbs.	Galv. W-Beam Guardrail Full Wrap End
G FHWBFE1-0200	18.60 lbs.	Galv. W-Beam Guardrail Flared End
H FHWBESO-0200	15.00 lbs.	Galv. W-Beam Guardrail Bridge Shoe
I FHTRI26-0200	61.00 lbs.	6' 3" Galv. W-Beam To Thrie-Beam Transition Rail
J FHWBXXR-0200	92.00 lbs.	12' 6" Galv. W-Beam Radius (XX) Guardrail Convex
K FHWBXXR-0201	92.00 lbs.	12' 6" Galv. W-Beam Radius (XX) Guardrail Concave
L FH06081-4001	14.00 lbs.	6" X 8" - 14" Composite Block (Steel Post)
M FH18530-6200	46.50 lbs.	30" W 6 X 8.5# Galv. Steel W-Beam Pedestal Post
N FH18572-6200	51.00 lbs.	6' W 6 X 8.5# Galv. Steel W-Beam Post
O FH18584-6200	59.50 lbs.	7' W 6 X 8.5# Galv. Steel Thrie-Beam Post

Domestic Steel Guardrail Hardware

Item #	Lbs. ea.	Description
P FH58125-2100	0.194 Lbs.	5/8" - 11 X 1 1/4" Galv. Splice Bolt
Q FH58020-2100	0.250 Lbs.	5/8" - 11 X 2" Galv. Post Bolt (Steel Post And Steel Block)
Q FH58100-2100	0.827 Lbs.	5/8" - 11 X 10" Galv. Post Bolt (Steel Post And Wood Block)
Q FH58180-2100	1.392 Lbs.	5/8" - 11 X 18" Galv. Post Bolt (Wood Post And Wood Block)
R 4934850-9909	1.050 Lbs.	3/4" - 10 X 8 1/2" Concrete Post Anchor
S FH58000-8200	0.175 Lbs.	5/8" - 11 Galv. Double Recessed Nut
T FH58000-6200	0.078 Lbs.	5/8" Galv. Flat Washer

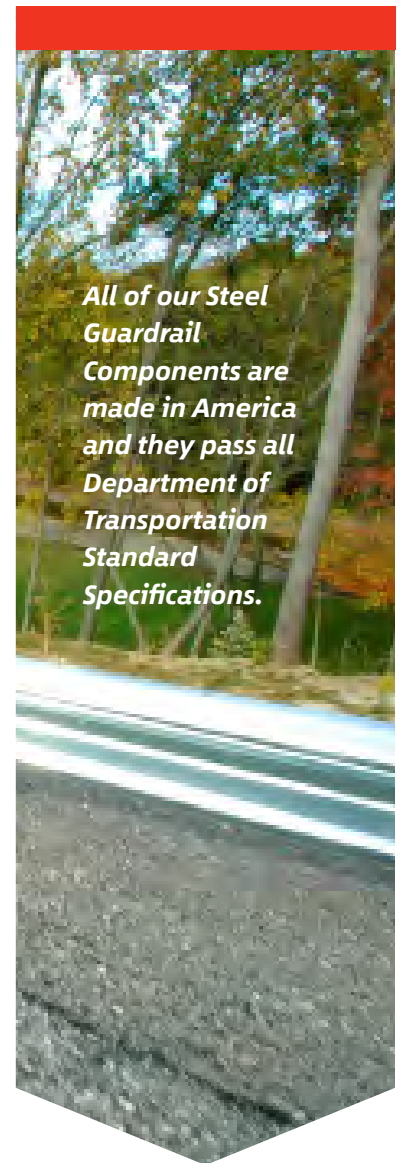

All of our Steel Guardrail Components are made in America and they pass all Department of Transportation Standard Specifications.

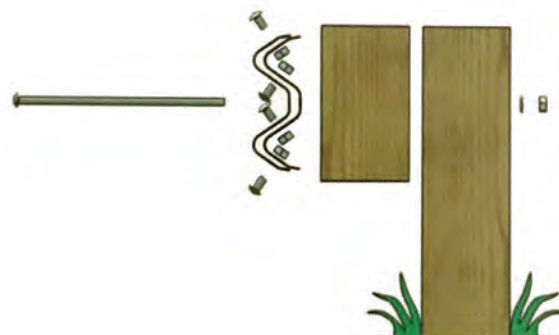
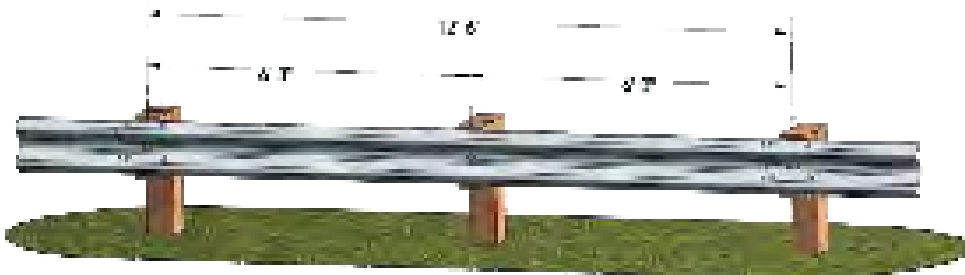



Used Guardrail



For a limited budget, consider used guardrail that our contractors have replaced even though it has never been hit or damaged and still retains years of service life.

Used Steel Guardrail

Item #	Lbs. Ea.	Description
A FHWB250-OU00	179.00 lbs.	25' Used 12 Ga. Galv. W-Beam Guardrail
B FHWB126-OU00	92.00 lbs.	12' 6" Used 12 Ga. Galv. W-Beam Guardrail
N FHI8569-6U00	51.00 Lbs.	5' 9" - 6' 5' 9" To 6' Used W6 X 8.5# Galv. Post

- Direct from state and federal highways
- Save up to 60% from new guardrail pricing
- High quality with minor flaws
- Some discolorization but no heavy rust
- Will provide years of service
- Perfect for developments and parking lots
- Great for live stock pens
- Full array hardware in stock





Powder Coated Guardrail

Powder coating over the same heavy duty, 12 gauge galvanized rails and components used in highway construction will add years of service life and assist in protection any where needed. Designed to withstand crashes with a pickup truck at 55 MPH may be more than required but will save you money over other systems.

Many businesses are showing off their company colors with vibrant Powdered Coated Guardrail of their corporate theme in their parking lots or buildings. The yellow color is perfect for high visibility and safety. While the green and brown colors are great for parks and scenic roadways by blending in rather than the standard silver guardrail.





Sign Posts

Our Texas and Ohio locations manufacture our Wood Sign Posts from Texas grown Southern Yellow Pine and then treat to .60 CCA meeting the American Wood Protection Association standards.

Our Sign Posts range in size from 4x4-8' through 6x8-28' with many sizes in stock and can be pre-drilled with bolt holes and/or breakaway holes for faster installation time.



Pontiac, Michigan

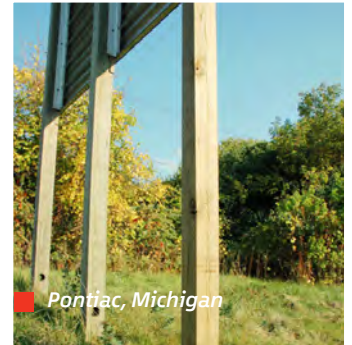

Pontiac, Michigan

Box Beam Sign Posts



Mansfield, Ohio

For a very strong and large sign post, American Timber and Steel manufactures Box Beam Posts utilizing layers of veneer, glued together into long panels. They are available as 8x8's and 8x15's up to 40 feet long and are easily field drilled and cut in order to be utilized as break-away supports.

The box beams are then treated with a Light Pentachlorophenol Type C to .50 retention meeting the American Wood Protection Association standards before they are stained and sealed to a very rich brown tone.



Milan, Ohio

8" X 8" Box Beam Sign Posts .50 Penta Type C

Lgth.	8" x 8"		8" x 15"	
	Item #	Lbs. ea	Item #	Lbs. ea
20'	0808208-6506	253.00 lbs		
22'	0808228-6506	278.30 lbs.		
24'	0808248-6506	303.60 lbs.	0814248-6506	461.25 lbs.
26'	0808268-6506	328.90 lbs.	0814268-6506	499.60 lbs.
28'	0808288-6506	354.28 lbs.	0814288-6506	538.11 lbs.
30'	0808308-6506	379.59 lbs.	0814308-6506	576.50 lbs.
32'	0808328-6506	404.90 lbs.	0814328-6506	615.00 lbs.
34'			0814348-6506	653.44 lbs.
36'			0814368-6506	691.87 lbs.
38'			0814388-6506	730.30 lbs.
40'			0814408-6506	768.75 lbs.

Microllam® LVL Breakaway Signpost

Type M Post



Type L Post

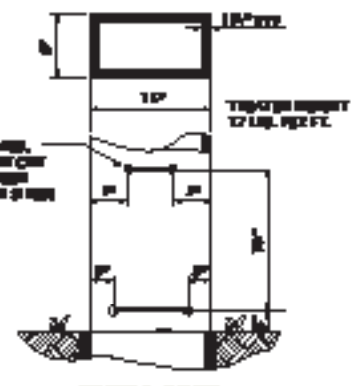



Timber Lagging

The versatility of Southern Yellow Pine makes it ideal for many applications of Timber Lagging in highway, industrial and commercial applications being the strongest domestic softwood although the reliable Douglas Fir timber or the old standby Mixed Oak timbers are also available.

American Timber and Steel can provide any timber specification in all grades from a low #3 to the highest grade of DS 65 or Select Structural and finishes as rough sawn or surfaced on all four sides. For stability and longevity, any of our treatment options are available CCA, CA-C, MCA, Pentachlorophenol or Creosote.

The chart lists our most common timbers but we can provide any of the many options available for timber lagging.



Clyde, Ohio



Berlin Heights, Ohio

#2 Southern Yellow Pine Rough Sawn .60 CCA Timber Lagging

Item #	Lbs. ea.	Description
0308082-1301	73.60 lbs.	3" X 8" - 8'
0408082-1301	98.13 lbs.	4" X 8" - 8'
0608082-1301	147.20 lbs.	6" X 8" - 8'
0808082-1301	192.00 lbs.	8" X 8" - 8'

#2 Mixed Oak Rough Sawn Untreated Timber Lagging

Item #	Lbs. ea.	Description
0308082-6001	96.00 lbs.	3" X 8" - 8'
0408082-6001	128.00 lbs.	4" X 8" - 8'
0608082-6001	192.00 lbs.	6" X 8" - 8'
0808082-6001	256.00 lbs.	8" X 8" - 8'

Landscape Timbers

SEE PAGES
42-43 FOR
HARDWARE



Huron, Ohio

For over 35 years, American Timber and Steel has been supplying big strong top quality Landscape Timbers for landscape professionals everywhere to use for retaining walls, flower beds, raised gardens, parking bumpers, stairways, and to line driveways.

These large timbers are nothing like the peeler core byproducts you may find elsewhere that will rot away after just a few years. Our Landscape Timbers are solid and are treated right lasting for decades whether treated for residential use in CA-C or MCA or CCA if for commercial use.

Listed are some of the more common sizes from 6x6 to 8x8 in either rough sawn for a more rustic look with timbers that may vary in size a bit or in surfaced timbers that are planed down making them a half inch smaller but gives a cleaner more uniform look.

Southern Yellow Pine Landscape Timbers

Item #	Lbs. ea.	Description
0606082-1700	91.20 lbs.	6" X 6" - 8' #2 SYP Surfaced 4 Sides .15 CA-C
0606082-1701	114.00 lbs.	6" X 6" - 8' #2 SYP Rough Sawn .15 CA-C
0608082-1700	121.60 lbs.	6" X 8" - 8' #2 SYP Surfaced 4 Sides .15 CA-C
0608082-1701	153.60 lbs.	6" X 8" - 8' #2 SYP Rough Sawn .15 CA-C
0808082-1700	162.13 lbs.	8" X 8" - 8' #2 SYP Surfaced 4 Sides .15 CA-C
0808082-1701	204.80 lbs.	8" X 8" - 8' #2 SYP Rough Sawn .15 CA-C



Huron, Ohio



Covered Bridge Timbers

As a leading manufacturer and supplier of materials for nearly 100 either rehabilitated or new covered bridges across America, we are proud to provide a small part in restoring these beautiful historical bridges.

American Timber and Steel is uniquely qualified from our extensive work over the years with Departments of Transportation across the country to custom saw, plane and treat to nearly any specification. Our experts are also able to help suggest "Real Life" alternatives when the materials or grades of years ago are not available today.



McConnells Mill | Portersville, Pennsylvania

Hueston Woods | College Corner, Ohio



Erskine | West Alexander, Pennsylvania



Medora | Vallonia, Indiana



Sawhill
Taylorstown, Pennsylvania



Woods | Center Township, Pennsylvania



Hemminger Farm | Elizabethville, Pennsylvania



Everhart | Harrisburg, Pennsylvania



Pottersburg | North Lewisburg, Ohio



Kramer | Orangeville, Pennsylvania



Claycomb Reynoldsville | Bedford, Pennsylvania



Bridge Decking

Our ability to supply an extensive array of unique sizes and strength requirements from large timbers to deck boards for Bridges and Bridge Decks has made us known as "The Timber Specialists."

American Timber and Steel specializes in both new construction and bridge rehabilitation projects meeting nearly any specification, size, finish or trim across the United States from private to city, county, state and federal bridges. We also have the expertise to suggest alternatives if the timber specified is not available.

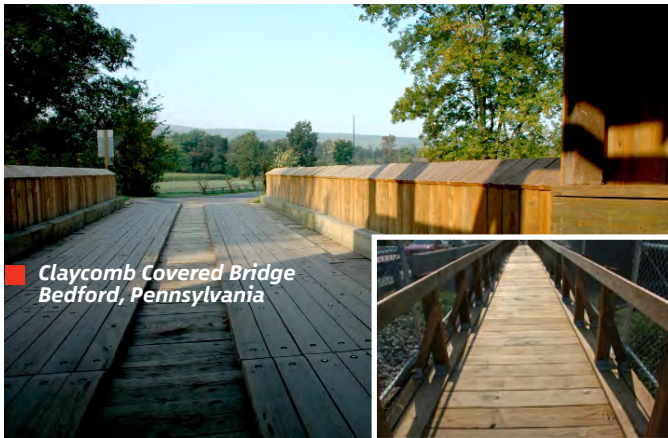

#2 Southern Yellow Pine Bridge Decking Surfaced 4 Sides .60 CCA

Item #	Lbs. ea.	Description
0304082-1300	28.80 lbs.	3" X 4" - 8'
0304122-1300	43.20 lbs.	3" X 4" - 12'
0304162-1300	57.60 lbs.	3" X 4" - 16'
0304202-1300	70.00 lbs.	3" X 4" - 20'
0306082-1300	43.20 lbs.	3" X 6" - 8'
0306122-1300	60.17 lbs.	3" X 6" - 12'
0306162-1300	86.40 lbs.	3" X 6" - 16'
0306202-1300	108.00 lbs.	3" X 6" - 20'
0406082-1300	56.00 lbs.	4" X 6" - 8'
0406122-1300	86.40 lbs.	4" X 6" - 12'
0406162-1300	112.00 lbs.	4" X 6" - 16'
0406202-1300	140.00 lbs.	4" X 6" - 20'
0408082-1300	76.80 lbs.	4" X 8" - 8'
0408122-1300	115.20 lbs.	4" X 8" - 12'
0408162-1300	149.35 lbs.	4" X 8" - 16'
0408202-1300	192.00 lbs.	4" X 8" - 20'

Bridge Building Timbers

With the ability to mill timbers even larger, we have supplied timbers as large as 10 inch x 30 inch and lengths up to 55 feet (for even larger sizes see, Laminated Timbers page).

Nearly every species and grade is available as well as almost all treatment options including both waterborne and oil-borne. The waterborne treatments consist of CCA, CA-C and MCA. The Oil-borne preservatives consist of Pentachlorophenol, Creosote and Copper Napthenate.

American Timber and Steel can also kiln dry our timbers after treatment in order to help stabilize and increase the wood's strength.



SEE PAGES 42-43 FOR HARDWARE





Golf Course and Bikeway Bridges

Some of our more scenic projects that American Timber and Steel has supplied timbers have been bridges for Golf Courses and Rails-to-Trails Bikeways. Project engineers and architects specify our quality timbers not only for their high strength and great looks but also because they are treated to last for decades.

These bridges typically require our high grade #1 or #1 Dense, Southern Yellow Pine with the support structure treated to .60 CCA and the upper structure treated to .15 or .31 CA-C. We then offer Kiln Drying After Treatment (KDAT) in order to strengthen and stabilize the wood.



Blacklick Creek Golf Course | Reynoldsburg, Ohio



John Craddock Wetland Preserve
Muncie, Indiana



Lehigh Gorge State Park
Glen Onoko Falls
Jim Thorpe, Pennsylvania

Golf Cart Bridge

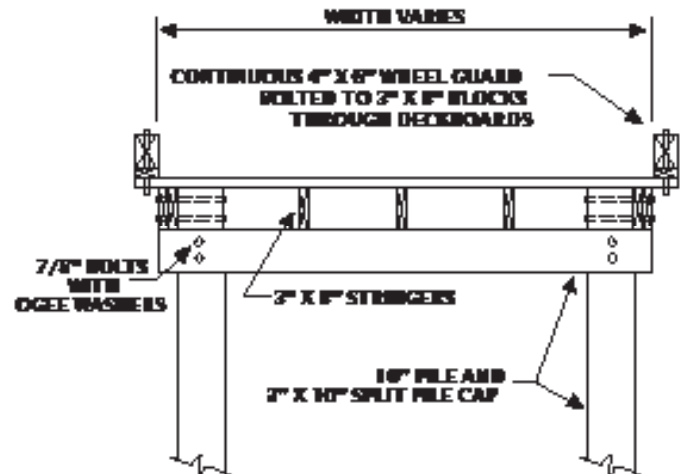

Drawing provided by the Southern Pine Council.



Sea Wall and Marine Timbers

Marine and Seawall timbers are another one of our specialty lines for such uses as Shoreline Stabilization, Structural Supports for Pier Docks, Wales, Chocks, Fender Poles, Bridge and Pier Fender Systems, Dolphin Clusters and Guide Walls for Locks and Dams.

We prefer the use of Southern Yellow Pine because of its strength and its ability to allow the chemical to penetrate deep within the timber for better protection but most other wood species are also available. We then treat with CCA, CA-C or MCA to the proper retention based on whether they application is for fresh water or salt water. Then to help stabilize, strengthen and reduce shrinkage, Kiln Drying After Treatment (KDAT) is an option.



Photo provided by Southern Pine Council



Thomas A. Edison Bridge
Bay View, Ohio

American Timber and Steel can meet any grade requirement needed for your project.



Salt Storage Bins

With strength being a prime concern for salt and sand storage buildings, engineers demand the high strength provided by Southern Yellow Pine and Douglas Fir Timbers making it our first choice as well.



Laminated Timbers

Laminated Timbers are a stronger and less expensive option than solid sawn timbers by making giant timbers out of smaller farm grown trees. They are manufactured in a couple different ways.

Laminated Veneer Lumber (LVL) are layers of veneer glued together like plywood designed for interior header beams and scaffold plank type applications. Our LVL's are available in 1¾ inch to 3½ inch thicknesses, widths from 7½ inch to 24 inch and lengths up to 60 feet but are designed for interior use only and are not treated.

Glulam's are pieces of lumber which are glued together to make a larger timber. They can be treated with CCA for exterior applications or untreated for interior use and are generally used as support beams and columns. Glulam's are available in 3¾ inch to 8¾ inch thicknesses, widths from 8¾ inch to 28¾ inch, while lengths are nearly unlimited.





Dimensional Lumber

American Timber and Steel stocks standard and high grade dimensional lumber for many uses like decks, docks, gazebos, fences, barns and boardwalks. Most sizes are stocked as brite (untreated) or treated with environmentally friendly CA-C or MCA.

We are one of the few treaters stocking all our material with this higher treatment for ground contact, enabling easy installation and the longest life as most projects will actually touch the ground.

Also available is Kiln Drying After Treatment (KDAT) to strengthen, reduce shrinkage after installation and to stabilize the wood.



Maumee, Ohio



Norwalk, Ohio



Port Clinton, Ohio

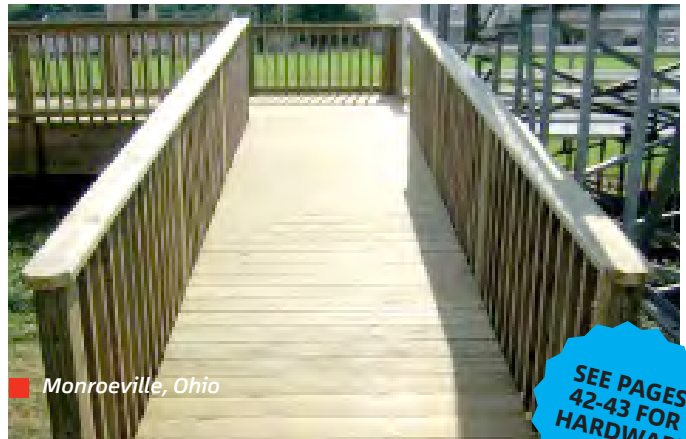

Monroeville, Ohio

SEE PAGES 42-43 FOR HARDWARE

.15 CA-C (Ground Contact) Stocked Items

Size #	Description	8'	10'	12'	14'	16'	20'	24'
1" X 4"	#2 SYP Surfaced Four Sides	AVAIL.		AVAIL.		AVAIL.		
1" X 6"	#2 SYP Surfaced Four Sides	AVAIL.		AVAIL.		AVAIL.		
5/4" X 6"	Premium SYP Radius Edge			AVAIL.		AVAIL.		
2" X 4"	#1 SYP Surfaced Four Sides	STOCK	AVAIL.	STOCK	AVAIL.	STOCK	AVAIL.	
2" X 6"	#1 SYP Surfaced Four Sides	STOCK	AVAIL.	STOCK	AVAIL.	STOCK	AVAIL.	AVAIL.
2" X 8"	#1 SYP Surfaced Four Sides	AVAIL.	AVAIL.	STOCK	AVAIL.	STOCK	AVAIL.	AVAIL.
2" X 10"	#1 SYP Surfaced Four Sides	AVAIL.	AVAIL.	STOCK	AVAIL.	STOCK	AVAIL.	AVAIL.
2" X 12"	#1 SYP Surfaced Four Sides	AVAIL.	AVAIL.	STOCK	AVAIL.	STOCK	AVAIL.	AVAIL.

● AVAIL. = Treat to order items | ● STOCK = Items in treated stock



Pole Barn Posts

After 35 years our pole barn posts and timbers continue to stand strong supporting our commitment to “treat to last.”

While nearly any size is available, we stock Southern Yellow Pine 4x4’s through 8x8’s ready to treat with CCA or environmentally friendly CA-C or MCA. The versatility of Southern Yellow Pine to hold more preservative and yet provide strength makes it a very reliable and cost effective choice.

Tongue and Groove 2x6 and 2x8 boards are also available for bottom splash boards along with a full line of pole barn products.



Norwalk, Ohio



Milan, Ohio



Wakeman, Ohio

.15 CA-C Tongue & Groove #1 SYP S4S (Ground Contact) Stocked Items

Size #	8'	10'	12'	14'	16'	18'	20'	24'
2" X 6"			AVAIL.		AVAIL.			
2" X 8"					AVAIL.			

.15 CA-C Timbers #2 SYP S4S (Ground Contact) Stocked Items

Size #	8'	10'	12'	14'	16'	18'	20'	24'
4" X 4"	STOCK		AVAIL.		AVAIL.			
4" X 6"	AVAIL.		AVAIL.		AVAIL.			

.15 CA-C Pole Barn and Landscape Timbers #2 SYP S4S (Ground Contact) Stocked Items

Size #	8'	10'	12'	14'	16'	18'	20'	24'
6" X 6"	STOCK	STOCK	STOCK	AVAIL.	STOCK		AVAIL.	
4" X 8"	STOCK	STOCK	STOCK	AVAIL.	STOCK			
8" X 8"	STOCK	STOCK	STOCK	AVAIL.	STOCK			

● AVAIL. = Treat to order items | ● STOCK = Items in treated stock





Metal Fabrication

American Timber and Steel is excited to officially announce our metal fabrication at our Norwalk, Ohio production facility. Our expanded equipment and abilities offer our customers greater innovation and design for customized metal product solutions.

Here are samples of varied engineered solutions we have designed and provided our customers or for our own use and we look forward to working with you, no matter how unique your project may be.



Rotating Bin to Hold 4'x8' Plywood Panels for Pressure Treatment that is Safer and Easier to Load and Unload

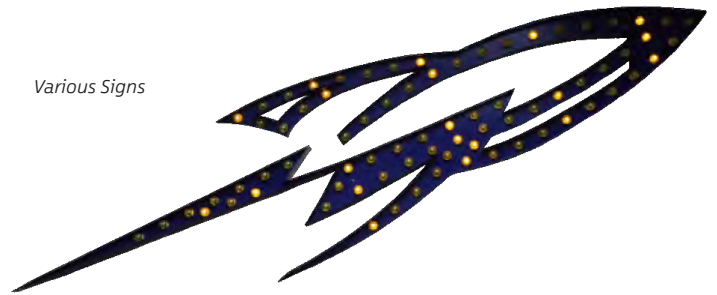

Various Signs



Press Break Tooling Cart





Stationary Recoiling Device for the Testing of Long-barreled Firearms



Repurposed Cast Iron Pulley into a Coffee Table



Reclaimed Wood Bowling Lane Table Top with Metal Fabricated Rocket Cutout Trestle Legs



Large Integrated Metal Shelf



Fasteners

The fasteners listed are stocked as imported hot dipped galvanized but we also have many options for stainless steel and domestic fasteners.

Hot Dipped Galvanized Hex Head Bolts "A"

Size	5/16"	3/8"	1/2"	5/8"	3/4"
3"	Stocked	Stocked	Stocked	Stocked	Stocked
3 1/2"	Stocked	Stocked	Stocked	Stocked	Stocked
4"	Stocked	Stocked	Stocked	Stocked	Stocked
4 1/2"	Stocked	Stocked	Stocked	Stocked	Stocked
5"	Stocked	Stocked	Stocked	Stocked	Stocked
6"	Stocked	Stocked	Stocked	Stocked	Stocked
8"		Stocked	Stocked	Stocked	Stocked
10"		Stocked	Stocked	Stocked	Stocked
12"		Stocked	Stocked	Stocked	Stocked
14"			Stocked	Stocked	Stocked
16"			Stocked	Stocked	Stocked

Hot Dipped Galvanized Carriage Bolts "B"

Size	5/16"	3/8"	1/2"	5/8"	3/4"
3"	Stocked	Stocked	Stocked	Stocked	Stocked
3 1/2"	Stocked	Stocked	Stocked	Stocked	Stocked
4"	Stocked	Stocked	Stocked	Stocked	Stocked
4 1/2"	Stocked	Stocked	Stocked	Stocked	Stocked
5"	Stocked	Stocked	Stocked	Stocked	Stocked
6"	Stocked	Stocked	Stocked	Stocked	Stocked
8"		Stocked	Stocked	Stocked	Stocked
10"		Stocked	Stocked	Stocked	Stocked
12"		Stocked	Stocked	Stocked	Stocked
14"			Stocked	Stocked	Stocked
16"			Stocked	Stocked	

Please call for pricing and availability.

Hot Dipped Galvanized Lag Bolts "C"

Size	1/4"	5/16"	3/8"	1/2"
3"	Stocked	Stocked	Stocked	Stocked
3 1/2"	Stocked	Stocked	Stocked	Stocked
4"	Stocked	Stocked	Stocked	Stocked
4 1/2"	Stocked	Stocked	Stocked	Stocked
5"	Stocked	Stocked	Stocked	Stocked
6"	Stocked	Stocked	Stocked	Stocked

Hot Dipped Galvanized Flat Washers "D"

	5/16"	3/8"	1/2"	5/8"	3/4"
Washers	Stocked	Stocked	Stocked	Stocked	Stocked

Hot Dipped Galvanized Hex Nuts "E"

	5/16"	3/8"	1/2"	5/8"	3/4"
Nuts	Stocked	Stocked	Stocked	Stocked	Stocked

Hot Dipped Galvanized Pole Barn Spikes "F"

4"	5"	6"	8"	10"	12"
Stocked	Stocked	Stocked	Stocked	Stocked	Stocked



A



B



C



D



E



F

Stainless Steel Star Drive Screws - CA-C Approved

Size	Description	Driver Size		
1 5/8"	#7 SS Trim Star Drive Screw	T15	Stocked	A
2 1/4"	#7 SS Trim Star Drive Screw	T15	Stocked	A
1 5/8"	#9 SS Star Drive Screw	T25	Stocked	B
2"	#9 SS Star Drive Screw	T25	Stocked	B
2 1/2"	#10 SS Star Drive Screw	T25	Stocked	B
3"	#10 SS Star Drive Screw	T25	Stocked	B
3 1/2"	#10 SS Star Drive Screw	T25	Stocked	B
4"	#10 SS Star Drive Screw	T25	Stocked	B

GRK Fasteners R4 Multi Purpose Star Drive Screws - CA-C Approved

Size	Description	Driver Size		
1 1/2"	#8 Trim Star Drive Screw	T10	Stocked	B
2"	#8 Trim Star Drive Screw	T10	Stocked	B
2 3/4"	#8 Trim Star Drive Screw	T10	Stocked	B
1 3/4"	#8 Star Drive Screw	T15	Stocked	C
2 1/2"	#9 SS Star Drive Screw	T25	Stocked	C
3 1/8"	#10 SS Star Drive Screw	T25	Stocked	C
3 1/2"	#10 SS Star Drive Screw	T25	Stocked	C
4"	#10 SS Star Drive Screw	T25	Stocked	C

GRK Fasteners Structural Star Drive Screws - CA-C Approved

Size	Description	Driver Size		
1/4" x 2 1/2"	Structural Star Drive Screw	T25	Stocked	D
1/4" x 3 1/2"	Structural Star Drive Screw	T25	Stocked	D
5/16" x 4"	Structural Star Drive Screw	T30	Stocked	D
5/16" x 6"	Structural Star Drive Screw	T30	Stocked	D
3/8" x 4"	Structural Star Drive Screw	T30	Stocked	D
3/8" x 6"	Structural Star Drive Screw	T30	Stocked	D
3/8" x 8"	Structural Star Drive Screw	T30	Stocked	D
3/8" x 10"	Structural Star Drive Screw	T30	Stocked	D
3/8" x 12"	Structural Star Drive Screw	T30	Stocked	D
3/8" x 14"	Structural Star Drive Screw	T30	Stocked	D
3/8" x 16"	Structural Star Drive Screw	T30	Stocked	D

Star Drive Torx Drivers "E"

	T10	T15	T20	T25	T30
Drivers	Stocked	Stocked	Stocked	Stocked	Stocked

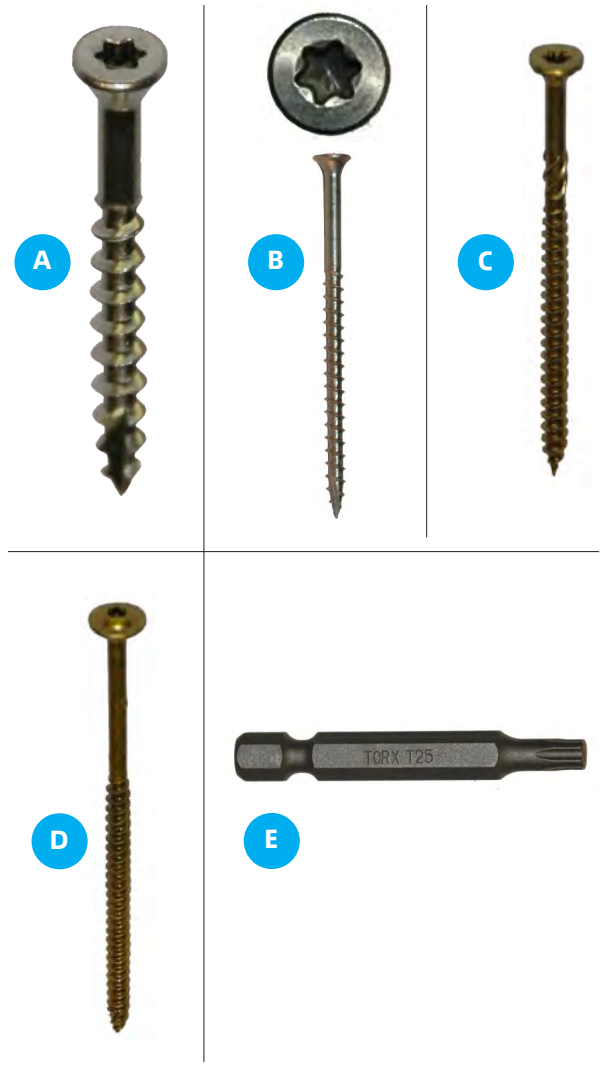



Twisted Manila Rope "A"

1/2"	3/4"	1"	1 1/4"	1 1/2"	2"
Stocked	Stocked	Stocked	Stocked	Stocked	Stocked



A

Hot Dipped Galvanized Chain "B"

1/4"	3/8"	1/2"
Stocked	Stocked	Stocked



B

Hot Dipped Galvanized Post Connector "C"

Stocked

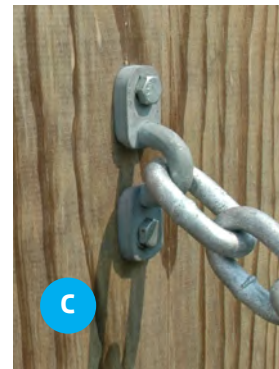

C

Steel Timber Pile Points "D"

5" - 10"	8" - 12"	11" - 15"
Available	Available	Available



D

Gallon of Copper Napthenate "E"

Stocked



E

Gate Hardware "F,G,H"

Loop Latch	Stocked	F
1/2" x 4" Screw Hook & Eye Hinge Set	Stocked	G
24" Cane Bolt (Drop Rod)	Stocked	H



F

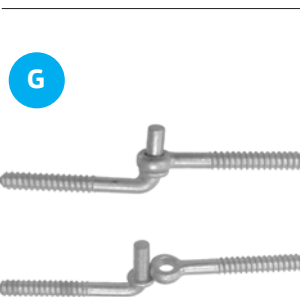

G



H



Product Resources

Additional Views
Product Guides
Material Safety Data Sheets (MSDS)

Online Help

Send an email
Request a phone call
Request a quote

No Minimum Order

We have no minimum order policy. Each order, large or small, is appreciated and shipped with the same care and attention.

Terms of Payment

We accept credit or debit cards for orders under \$10,000, including Visa, Mastercard, American Express and Discover. For orders above \$10,000 payment can be made via Wire Transfer, ACH or Certified Check. Personal and Company checks are only accepted upon approval by the Credit Department. Contact your sales representative to obtain banking information for electronic payments.

Credit Accounts*

Become a member of our family. One of our friendly and knowledgeable sales associates will be assigned to your account. Once your credit application has been completed and approved you will be able to purchase items on account and have the flexibility to pay within our stated credit terms.

*Additional terms and conditions are required, and all accounts are subject to credit approval.

Pricing

All shipments will be processed at prices prevailing at the time of order confirmation. Price quotes are valid for 7 days, unless otherwise noted.

Product Information

Product specifications, dimensions, capacities, weights, etc. are kept as up-to-date as possible, but are also subject to change without notice. There may be slight dimensional variations due to the nature of wood and many of our components being hand made. For specific product information or measurements, please contact an American Timber and Steel representative. American Timber and Steel makes no warranty concerning the merchantability of the products or their suitability or fitness for any particular purpose or use.

Shipping

All orders are shipped as close to the scheduled shipping date as possible. All orders are F.O.B. our warehouses. Shipments may be subject to additional charges such as residential delivery, lift gate service, COD fees, oversize shipment, re-consignment, metro delivery, and other fees.

Claims & Returns

Please inspect the shipment immediately.

1. Upon receipt of order, damages, overages, and shortages must be reported within 5 business days of receipt by notifying American Timber and Steel at 800-551-9663.
2. Retain the merchandise AND packing material for inspection by the carriers.
3. In order to receive replacement product or to file a claim, shortages and/or damages must be noted on the bill of lading at the time of delivery by the individual receiving the shipment. Any damage or loss incurred in transit is the responsibility of the carrier.
4. All claims must be made before installation, use or alteration of the product. Cutting, drilling, planing, painting, staining or altering the product in any way, without written authorization by American Timber and Steel, voids all claims.

Returned Goods

Prior to returning material for any reason, you must contact our Customer Service Department at 800-551-9663. An RMA number (Return Material Authorization number) is required for all returns. Returns unaccompanied by an RMA cannot be accepted. For prompt credit processing, please put the RMA number on the packaging. Stock items ordered in error may be returned freight prepaid for credit within 30 days subject to a 20% restocking fee or \$10 minimum. We will be pleased to issue an in-store credit upon American Timber and Steel's inspection and approval. Special ordered items cannot be returned. Returns over 30 days from invoice date will not be accepted. Please have your invoice on hand when calling. **Any product cut, drilled, painted, or altered in any way by the customer is non-returnable.** Any loss incurred for labor, time and shipping is not covered. American Timber and Steel has no control over end products fabricated with the products purchased from American Timber and Steel or the installation procedures used. No warranty is expressed or implied. All material must be inspected for quality before installation. If further details are required, please contact us.

Back Orders

Items that are out of stock will be automatically back ordered and shipped as soon as they are available, F.O.B. our warehouses. Any unwanted back orders should be cancelled immediately.

Warranty & Liability

All merchandise is produced to standard and commercial tolerances. American Timber and Steel warrants its products to be free from defects in workmanship and material. No other warranty is expressed or implied. In particular, American Timber and Steel makes no warranty concerning the merchantability of the products or their suitability or fitness for any particular purpose or use. The customer is responsible for testing and verifying the suitability of the product for its intended use. American Timber and Steel's liability is limited at our election to (1) issue of in-store credit of Buyers purchase price, (2) replacement of such products, or (3) repair of such products. American Timber and Steel is not liable for any loss, damage, or compensation from the use of the product.

Technical Advice

American Timber and Steel makes no warranty of results obtained as a result of technical advice furnished by American Timber and Steel. The customer shall test and verify suitability for intended use. All drawings and dimensions shown in the catalog are for reference only.

**What is pressure treated wood?**

Pressure treated wood is wood that has been put through a process which forces chemicals, under pressure, into the wood. These chemicals are generally either a wood preservative, which gives the wood a longer service life, or a fire retardant, which inhibits the spread of flames.

What common preservatives are used to treat pressure-treated wood?

The American Wood Protection Association Standards provide a complete list of accepted standard formulations in the US. Copper Azole Type-C (CA-C), Chromated Copper Arsenate (CCA), Alkaline Copper Quat (ACQ), Micronized Copper Azole (MCA), Ammoniacal Copper Zinc Arsenate (ACZA), Pentachlorophenol and Creosote are the most widely used systems.

Can I use any preservative treated wood anywhere?

All wood preservatives are regulated by the United States Environmental Protection Agency (EPA). The EPA approves labeling of the wood preservatives, which allows certain uses for each chemical preservative. Some preservatives have their uses restricted to specific commercial and industrial applications, while others can be used in residential applications. In order to remain within the EPA guidelines and determine which preservatives and how much preservative may be used, we must follow the American Wood Protection Association (AWPA) Use Category System. For more information visit the AWPA website at www.awpa.com

What are the American Wood Protection Association (AWPA) and the Use Category System (UCS)?

The AWPA is an international, non-profit, technical society founded in 1904 to provide a common forum for exchange of technical information between industry, research and users of treated wood. AWPA is the principal standards writingbody for the wood preserving industry in the United States. Individuals with various areas of interest including consumers, users, government, academia, specifiers and producers meet on a regular basis to develop and maintain standards for preservatives, treatment, testing methods, quality control and inspection of treated wood products.

The AWPA Use Category System (UCS) specifies the wood treatment required based on many variables including the product, desired wood species and the environment or hazard exposure of the intended end use. There are six Use Categories, including fire retardant applications, which describe the exposure conditions that wood may be subject to in service. Each exposure has a different degree of biodegradation hazard and/ or product service-life expectation. The system helps specifiers and product users locate the appropriate AWPA Standards that provide recommendations for a specific combination of product and environment.

All treated wood commodities can be placed into one of the Use Categories based on exposures and expected product performance. The user of the UCS should first find the appropriate Use Category for the expected service conditions and planned applications in the Specification Guide to Treated Wood End Uses.

Generally, as the category number rises, there is a consequent increase in the required preservative retention or limitation of preservative types. The dimensions of the treated product may also influence the depth-of-penetration requirement. The lower the Use Category number, the least amount of protection is required as it relates to the level of protection necessary for decay or insect attack. Conversely, the highest Use Category number provides the highest degree of protection to wood used in the most severe conditions.

For more information concerning the AWPA Use Category System, contact us or visit the AWPA website at awpa.com

What is CCA?

CCA stands for Chromated Copper Arsenate, a wood preservative formulation containing copper, chromium and arsenic. The copper acts as the main fungicide and also provides some protection against termites. Arsenic provides protection against termites and copper-tolerant decay fungi. Chromium helps to bond and "fix" the chemical components to the wood.

CCA pressure-treated wood is protected from rot, decay and termite attack with Chromated Copper Arsenate (CCA) wood preservative. Generally, the label authorizes use of CCA in most industrial, commercial and farm applications. Most of those applications are heavy retention treatments of 0.50 or more pounds per cubic foot. Some examples of CCA uses that are permissible: Lumber and Timber for Salt Water Use, Piles, Poles, Plywood, Wood for Highway Construction, Poles, Piles and Posts (including fence posts) used as structural members on farms, Wood for Marine Construction, Lumber and Plywood for Permanent Wood Foundations, Round Poles and Posts Used in Building Construction, Sawn Timber Used to Support Residential and Commercial, Structures, Sawn Crossarms, Structural Glued-Laminated Members and Laminations before Gluing, Structural Composite Lumber, Shakes and Shingles.

What is CA-C?

CA-C stands for Copper Azole Type C using 2 Azoles (an organic triazole co-biocides of propiconazole and tebuconazole) as the primary biocide to help control attack from copper tolerant fungi. CA-C has gained popularity as an environmentally friendly and people friendly alternative and meets the stringent industry standards of the American Wood Protection Association (AWPA) for a wide variety of residential, commercial, and agricultural projects from UC3A through UC4C ratings.

CA-C has a long history of effectiveness in wood preservation, can be used in unlimited applications and can be painted or stained after it has been properly dried. The most common treatment retention is .15 for general ground contact use.

What is ACQ?

ACQ stands for Alkaline Copper Quat, a wood preservative formulation that contains copper and quaternary ammonium compound (quat) as active ingredients. The copper plus quat preservative system provides long-term protection from rot, decay, and termites.

ACQ has been widely used as a cost-effective and environmentally friendly fungicide protecting against decay until 2020 when the availability of quat became an issue as the demand for sanitizers and disinfectants increased.

What is MCA?

MCA stands for Micronized Copper Azole, which contains micronized copper and tebuconazole dispersed in water. This copper based preservative is approved for residential, commercial and industrial applications.

This preservative is also a more "environmentally friendly" alternative, and readily accepts paint or stain after it has been properly dried. This preservative is also less corrosive than CA-C treated wood products.

What is ACZA?

ACZA stands for Ammoniacal Copper Zinc Arsenate, a wood preservative formulation containing copper, zinc and arsenic, dissolved in a solution of ammonia and water. ACZA is a wood preservative generally in use in the western US. Because ACZA contains arsenic, it is generally used for commercial and industrial applications.

What is Pentachlorophenol?

Pentachlorophenol is a minimum of 95% chlorinated phenols. Pentachlorophenol is generally used to treat Utility Poles, Sign Posts, Bridge Structures and a few other industrial applications.

What is Creosote?

Creosote is specified as a distillate derived entirely from tar produced by the carbonization of bituminous coal.

Creosote is generally used in commercial and industrial applications such as Utility Poles, Railroad Ties, Farm Fence Posts and for Marine Piling. When used properly, creosote-treated industrial wood products perform vital functions without creating any demonstrable scientific risk of chronic health problems or damage to the environment. Creosote-treated wood products have been making a valuable contribution to the nations transportation, communications, energy, and maritime infrastructures for more than a century. In terms of performance and cost, creosote-treated wood products deliver benefits that cannot be matched by substitutes.

Today's strong health and environmental safety record of creosote-treated wood is a result of modern production and treatment technologies, strict adherence to Federal requirements, and commitment by the makers and users of creosote to the latest and best practices available, all backed up by good science. For more information about creosote, please explore the creosote council website at creosotecouncil.org.

What treatment chemical and retention level should I use?

For most residential uses and applications with regular human contact, we recommend CA-C or MCA treated wood. For commercial, industrial and farm applications, we generally recommend either CA-C or CCA. Our recommendations follow the AWWPA standards plus the experience of the industry uses for longevity as well as consumer cost awareness.

Treatment retentions are different depending upon the chemicals used. For example, for the most common treatment CCA, the recommended minimum retention is .40 for above ground use, .50 for ground contact, .60 for heavy duty or higher for water uses. Whereas, for CA-C treatment the recommended minimum retentions are .06 for above ground use, .15 for general ground contact and .31 or higher for heavy duty or water uses.

CCA, CA-C, Creosote, Pentachlorophenol and ACZA treatments are recommended for many specialized industrial applications, particularly for Utility Poles and Railroad Ties. Treatment retentions vary, depending upon the final use. Contact us for more information.

Installation & Maintenance of Pressure Treated Wood

What safety precautions should be used when I am working with treated wood?

Material Safety Data Sheets (MSDS) are available at no charge for all of our products by calling us at 800-551-9663. Most are also available on our website at amtim.com.

Always wear gloves when handling any treated wood. Always wash your hands with soap and water before eating or smoking, after you have handled treated wood. All sawdust, whether treated or not, is hazardous and should not be ingested. Always use a dust mask when sawing treated wood.

What should I do with my cut off ends, sawdust and waste wood?

Check with your local landfill to see if there are any restrictions concerning disposal, however, in most areas the scrap can be disposed of through normal waste collection and disposal methods. **NEVER BURN TREATED WOOD.**

What should I do with my old deck or fence I tore down?

Recycle, recycle, recycle. While your old treated deck may not look pretty, it probably still has a useful life left and someone would be glad to have it. In most cases, the bottom side of your deck boards

still look great. Use the timbers for landscaping. Make some raised flower beds. If you don't have a use, call a wildlife rehab center or animal shelter. They need lots of cages.

If you can't find a way to recycle, dispose of it as you would your waste wood as described above.

What type nails or screws do you recommend?

Hot dipped galvanized and stainless steel fasteners are suitable for use with all preservative treated wood. There are also a number of new-coated fastener systems available. Be sure your fasteners are approved for the chemical used to treat your wood.

Should I paint, stain or seal my treated wood project?

In order to maintain a nice appearance, we recommend that you do provide regular care for most of your CA-C, CCA, MCA and ACZA pressure treated wood projects. While you may prefer to allow your project to age and gray naturally, properly applied coatings help prevent splitting, cracking and splintering of the treated wood. Wood treated with Creosote and Pentachlorophenol do not accept or require this maintenance.

How long do I need to wait before I paint, stain or seal my treated wood project?

Pressure treatment with waterborne preservatives leaves moisture in the wood that can affect the penetration and drying of stains and paint. For optimal performance of a paint, stain or seal coating, it is important to ensure the treated wood is dry and clean prior to the application. How long treated lumber will take to dry will depend on the time of year and the weather conditions. In general, allow at least one month in the summer or dry climates. Allow up to three months in moderate weather. Very little drying occurs in wet or winter weather. If possible, test for wood dryness on a scrap piece to see if the finish applies properly.

How often should I paint, stain or seal my treated wood project?

All coatings are different and we recommend that you follow the manufacturers instructions. In general, paint should be reapplied whenever it begins to peel. Stains are generally for appearance only and provide little protection from splitting and cracking. Stains should be applied before a sealant, although many stains and sealants are combined. Sealants generally need to be applied every one to three years for optimal performance.

What do you recommend I use to paint, stain and seal my treated wood project?

We recommend you use a good quality oil-based product. Transparent or semi-transparent products work best. Solid products just lie on the wood and do not move with it. This results in peeling. We cannot recommend brand name products, however Consumer Reports published their findings in the June 1999 issue.

Should I use concrete to set my posts?

The question of whether to use concrete or not has been around for quite a while. Tests have been conducted to determine whether concrete causes the wood to fail and the results were inconclusive. In New Zealand, the government requires that the poles holding up houses be set in concrete. They've not had any problems.

How do I remove the grade stamp from my deck?

A light sanding will lighten it somewhat, but you will really have to wait for it to fade with time.

What do you recommend I use to clean my deck?

There are many products in the marketplace that work very well. Or, you can use soap and water with a brush. To remove mildew, we recommend oxygen bleach, such as Oxy Clean which is less hazardous to plants and animals, or, use a diluted solution of Clorox bleach (3 parts water to 1 part bleach). Be very careful, as this could be toxic to plants, animals and humans. Any bleach will lighten wood.



NORWALK, OHIO



NACOGDOCHES, TEXAS



5 Star Split Rail Fencing	8, 9	Guardrail W-Beam Steel Rail	26, 27, 28	Sign Supports Wood Breakaway	30
5 Star Round Rail Fencing	7	Guide Rail Systems	16-19	Southern Yellow Pine Fence Boards	6
Agricultural Fence Boards	6	Hanging Signs	13	Southern Yellow Pine Round Rail Fencing	7
American Timber Rail	18, 19	Hex Head Bolts	42	Southern Yellow Pine Split Rail Fencing	8,9
Bikeway Bridges	35	Hex Nuts	22, 23, 42	Southern Yellow Pine Timbers	31
Blank Posts	2,3,14,15,17	Kentucky Board Fence	6	Splice Bolts	22,23,26,27
Board Fencing	6	Lag Bolts	42	Split Rail Fencing	8, 9
Bollards	14, 15	Lagging Timbers	31	Split Rail Gates	8, 9
Bolts	17, 23-25, 42	Laminated Timbers	37	Split Rail Hardware	9, 44
Box Beam Sign Posts	30	Landscape Timbers	31	Square American Timber Rail	18
Bridge Building Timbers	32-34	Log Rail	20	Square Bollards	15
Bridge Decking	34	Marine Timbers	36	Steel Guardrail	26-29
Carriage Bolts	42	Manila Rope	44	Steel Guardrail Posts	26, 27, 28
Chain	14, 15, 44	Merritt Parkway Guardrail	21	Steel Plates	18,19,22,23
Collapsible Bollards	15	Metal Fabrication	40, 41	Steel-Backed Timber Guardrail	22, 23
Color Powder Coated Guardrail	29	Mortised Post and Rail Systems	16, 17	Steel-Backed Timber Guardrail Hardware	22,23
Copper Napthenate	44	Mortised Posts	16, 17	Steel-Backed Timber Guardrail Offset Blocks	22,23
Covered Bridge Timbers	32, 33	Notched Post and Rail Systems	16, 17	Steel-Backed Timber Guardrail Plates	22,23
Decking - Bridge	34	Notched Posts	16, 17	Steel-Backed Timber Guardrail Posts	22,23
Decking - Decks	38	No Tapered Poles	12, 13	Steel-Backed Timber Guardrail Rails	22,23
Dimensional Lumber	38	Nuts	22, 23, 26, 27, 42	Steel-Backed Timber Guardrail Terminals	22,23
Dockside Bollards	14	Oak Fence Boards	6	Steel Fabrication	40, 41
Dome Top Posts	4, 14, 19	Oak Timbers	31	Steel Signs	13
Entrance Poles	13	Piling Points	44	Telephone Poles	11
Entrance Signs	13	Pilings	10, 36	Terms and Conditions	45
Faced Posts	5	Plate Washers	22, 23	Timber Lagging	31
Fence Boards	6	Pointed Posts	4	Timbers	31-37,39
Fence Posts	2, 3	Pole Barn Posts	39	Tongue and Groove Lumber	39
Fencing	2-9	Pole Barn Spikes	42	Turned Dome Top Posts	4, 14
Flat Washers	23, 26, 27, 42	Pole Barn Timbers	39	Turned Faced Posts	5
Frequently Asked Questions	46, 47	Poles	11, 12	Turned Fence Posts	2, 3
Gates	7-9	Poplar Fence Boards	6	Turned Piling	12
Glulams	37	Post Connector	44	Turned Poles	12, 13
Golf Course Bridges	35	Powder Coated Guardrail	29	Used Guardrail	28
Guardrail Breakaway Posts	24, 25	Product Locator	1	Utility Poles	11
Guardrail Delineator Reflector	26,27	Ranch Entrance Timber Kits	13	Washers	22, 23, 26, 27, 42
Guardrail Flared End	26, 27	Rectangular Washer	27	Wood Piling	10, 12
Guardrail Full Wrap	26, 27	Reflectors	26, 27	Wood Signs	13
Guardrail Half Wrap	26, 27	Rope	44	Yellow Poplar Fence	6
Guardrail Nuts	22, 23, 26, 27	Round American Timber Rail	19		
Guardrail Offset Blocks	22-25, 27	Round Bollards	14		
Guardrail Posts	22-28	Round Fence Posts	2-5		
Guardrail Radius Steel Rail	24, 26, 27	Round Piling	10		
Guardrail Steel Bolts	22, 23,26,27	Round Poles	11, 12		
Guardrail Transition Rail	26, 27	Round Post Stocking Locations	2		
Guardrail Washers	22, 23,26,27	Round Rail Fencing	7		
Guardrail Stocking Locations	25	Round Rail Gates	7		
Guardrail Thrie Beam Steel Rail	26, 27	Round Steel Backed Timber Guardrail	23		
Guardrail Wood Offset Blocks	22-29	Salt Storage Bins	37		
Guardrail Wood Posts	16-19, 22, 23,24-29	Screws	43		
Guardrail Wood Rails	16, 17, 22, 23	Sea Wall Timbers	36		
Guardrail Wood Routed Offset Blocks	24, 25, 27	Sign Posts	30		
Guardrail Systems (Guide Rail)	16-19	Sign Supports Laminated Wood Box Beam	30		



4832 PLANK ROAD
NORWALK, OHIO 44857

1.800.551.9663
419.668.7537 F

- GUARDRAIL PRODUCTS
- TIMBER BARRIER PRODUCTS
- ROUND FENCE POSTS
- SPLIT RAIL & ROUND RAIL
- BRIDGE TIMBERS
- POLES & PILINGS
- LUMBER & BUILDING MATERIAL
- HARDWARE
- METAL FABRICATION



CUSTOMERS' CUSTOM DESIGN PROJECTS



NUTTLEMANS FENCING
KEARNEY, NE



LANCASTER COUNTY TIMBER FRAMES
GEORGETOWN, WASHINGTON DC



NORTHWAY FENCE
MENOMONEE FALLS, WI

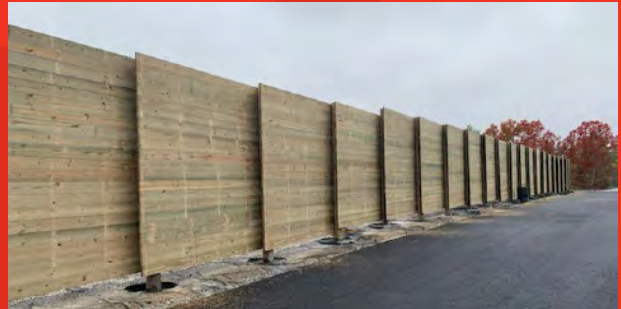

WEST MEMPHIS FENCE
WEST MEMPHIS, AR